



## Flänsad skyddsficka med speciell material på mediaberörda delar

L	D	RD	f	Tryckklass	Mediaberörd del	Best nr
100	66	12	2	DN25/PN40	Titan	67RÖRS0461
160	66	12	2	DN25/PN40	Titan	67RÖRS0462
250	66	12	2	DN25/PN40	Titan	67RÖRS0463
400	66	12	2	DN25/PN40	Titan	67RÖRS0464
700	66	12	2	DN25/PN40	Titan	67RÖRS0467
100	66	12,7	2	DN25/PN40	Hastelloy C22	67RÖRS0471
160	66	12,7	2	DN25/PN40	Hastelloy C22	67RÖRS0472
250	66	12,7	2	DN25/PN40	Hastelloy C22	67RÖRS0473
400	66	12,7	2	DN25/PN40	Hastelloy C22	67RÖRS0474

Mått i mm

### Klämförskruvning G1/2"

Rör $\varnothing$ (mm)	G	Best nr	Material
1,5	G1/2"	68FSK00207	AIS 316
3	G1/2"	68FSK00265	AIS 316
4,5	G1/2"	68FSK00261	AIS 316
6	G1/2"	68MTG00113	AIS 316
8	G1/2"	68FSK00244	AIS 316

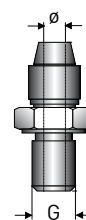

### Klämförskruvning G1/4"

Rör $\varnothing$ (mm)	G	Best nr	Material
1,5	G1/4"	68FSK00262	AIS 316
3	G1/4"	68FSK00243	AIS 316
4,5	G1/4"	68MTG00115	AIS 316
6	G1/4"	68FSK00235	AIS 316
6	G1/4"	68FSK00242	Mässing
8	G1/4"	68FSK00210	AIS 316

### Klämförskruvning G1/8"

Rör $\varnothing$ (mm)	G	Best nr	Material
1,5	G1/8"	68MTG00116	AIS 316
3	G1/8"	68FSK00219	AIS 316
4,5	G1/8"	68FSK00263	AIS 316
6	G1/8"	68FSK00220	AIS 316
8	G1/8"	68FSK00264	AIS 316

### Klämförskruvning

G	$\varnothing$	L	Best nr	Material
M8	3	35	68FSK00236	Syrafast stål

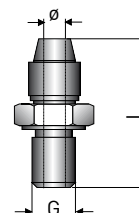

### Klämförskruvning med slitsad hylsa (klämhylsa)

Rör $\varnothing$ (mm)	G	Best nr	Material
3,1	G1/4"	68FSK00252	AIS 316
6	G1/4"	68FSK00248	AIS 316
8	G1/4"	68FSK00249	AIS 316
6	G1/2"	68FSK00300	AIS 316

## Klämförskruvning

Rör $\varnothing$ (mm)	G	L <sub>1</sub>	L <sub>2</sub>	Best nr	Max.tryck	Material
12	G1/2"	50	15	68FSK00240	450 bar	Syrafast stål
15	G1/2"	50	15	68FSK00215	450 bar	Syrafast stål
15	G3/4"	60	20	68FSK00237	1 bar	Stål
15	G1"	70	20	68FSK00238	1 bar	Stål
19	G3/4"	60	20	68FSK00245	1 bar	Stål
21/22	G1"	70	20	68FSK00239	1 bar	Stål

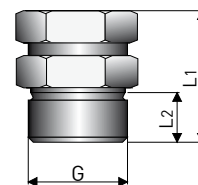

## Tätning till klämförskruvningar

$\varnothing$ (mm)	Best nr	Material
1,5	68OLV00015	PTFE Teflon Oliv
3	68OLV00030	PTFE Teflon Oliv
4,5	68OLV00045	PTFE Teflon Oliv
6	68OLV00060	PTFE Teflon Oliv
8	68OLV00080	PTFE Teflon Oliv
10,0	68OLV00100	PTFE Teflon Oliv
12,0	68OLV00120	PTFE Teflon Oliv

## Skjutbar fläns enligt DIN 43734

Typ	Rör $\varnothing$	D	d	Best nr	Tätning
Skjutbar fläns	15	55	-	68FLS00118	Ingen
Komplett med motfläns	15	55	35	68FLS00115	1 bar
Komplett med motfläns	21/22	70	40	68FLS00116	1 bar
Komplett med motfläns	32	70	50	68FLS00117	1 bar

Flänsarna fästes ihop med 2 st M8-bultar. (Medlevereras endast komplett flänspaket)

**Material**  
 Skjutfläns: Lackerat gjutjärn  
 Motfläns: Lackerat stål 1.0401

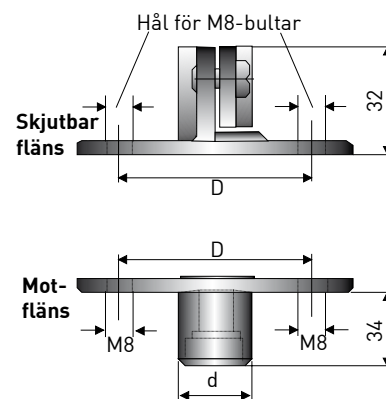

## Termokontakt

Standard			
Typ	Max.temp.	Stift	Hylsa
J	120 °C	68MTK01112	68MTK01111
K	120 °C	68MTK02112	68MTK02111
S	120 °C	68MTK03112	68MTK03111
N	120 °C	68MTK08112	68MTK08111
K	600 °C	68MTK02132	68MTK02131
S	600 °C	68MTK03132	68MTK03131
N	600 °C	68MTK08132	68MTK08131

Mini (120 °C)			
Typ	Stift	Hylsa	Chassi
J	68MTK01122	68MTK01121	68MTK01221
K	68MTK02122	68MTK02121	68MTK02221
S	68MTK03122	68MTK03121	68MTK03221
N	68MTK08122	68MTK08121	68MTK08221

