



IPAQ

C520 / C520N / C520X
R520 / R520N / R520X

HANDBOOK

HART
COMMUNICATION PROTOCOL

SIL2

CE

Ex

5 YEAR WARRANTY

INOR

INOR

SPECIALISTS IN INDUSTRIAL TEMPERATURE MEASUREMENT

Copyright

All rights reserved. Any duplication of this documentation or extracts thereof by any means is prohibited without prior written consent from

Inor Process AB

Subject to change without notice.

Version A, Copyright 2009 by

Inor Process AB • Slipstensgatan 6 • SE-20039 Malmö, Sweden

Tel. +46 (40) 312560

1	Safety instructions	5
1.1	Intended use.....	5
1.2	Product liability and guarantee.....	5
1.3	Certifications.....	5
1.3.1	Certification IPAQ C520X	5
1.3.2	Certifications IPAQ C520N	6
1.3.3	Certifications IPAQ R520X.....	6
1.3.4	Certifications IPAQ R520N	6
1.3.5	SIL Certifications	6
1.3.6	EC directive compliances	6
1.4	Manufacturer's safety instructions	7
1.4.1	Notes about the documentation	7
1.4.2	Symbol conventions.....	7
2	Device description	8
2.1	General description	8
2.2	Identification	9
3	Installation	10
3.1	Installation of the C520/C520N/C520X	10
3.2	Installing the R520/R520N/R520X.....	12
4	Electrical connections	13
4.1	Safety instructions.....	13
4.2	C520/C520N/C520X connections.....	13
4.3	Connection diagram C520.....	16
4.4	Connection diagram C520X.....	17
4.5	R520/R520N/R520X connections	18
4.6	Connection diagram, R520.....	22
4.7	Connection diagram, R520X.....	23
4.8	Cable length.....	23
5	Operation	25
5.1	C520/R520 in HART network.....	25
5.2	Configuration of the C520/C520N/C520X / R520/R520N/R520X	26
5.3	Configuration alternatives	28
5.3.1	Configuration of the 520 series transmitters with ConSoft	29
5.3.2	Configuration of the 520 series transmitters with handheld communicators FC 375/FC47532	32
5.3.3	Device management software's	32
5.3.4	Configuration with PACTware.....	33
5.4	Current output and HART dynamic/device variables	33
5.5	Diagnostic information according to NAMUR NE 107	34
5.6	Sensor failure monitoring according to NE43	36
5.7	Factory configuration and calibration of the C520/C520X / R520/R520X	36
6	Technical data	37
6.1	C520 specifications.....	37
6.1.1	Technical data	37
6.1.2	Output load diagram	38
6.1.3	Dimensions.....	38
6.1.4	Output and input data	39
6.1.5	Ambient temperature data for areas with potentially explosive atmospheres	39
6.2	C520X specifications.....	40
6.2.1	Technical data	40

6.2.2	Output load diagram	41
6.2.3	Dimensions	41
6.2.4	Output and input data	42
6.2.5	Ambient temperature data for areas with potentially explosive atmospheres	42
6.3	R520 specifications.....	43
6.3.1	Technical data	43
6.3.2	Output load diagram	44
6.3.3	Dimensions	44
6.3.4	Output and input data	45
6.3.5	Ambient temperature data for areas with potentially explosive atmospheres	45
6.4	R520X specifications.....	46
6.4.1	Technical data	46
6.4.2	Output load diagram	47
6.4.3	Dimensions	47
6.4.4	Output and input data	48
6.4.5	Ambient temperature data for areas with potentially explosive atmospheres	48
6.5	RTD and T/C accuracy table for C520/C520X / R520/R520X transmitters	49
7	Service.....	50
7.1	Ordering information.....	50
7.2	Disposal	50
7.3	Maintenance.....	50
7.4	Product liability and guarantee.....	51
7.5	Support	51

1.1 Intended use

The C520 is an intelligent, universal HART-compatible two-wire in-head transmitter for temperature, resistance or voltage measurements in an industrial environment. It is available with a Non-Incendive approval for use in potentially explosive atmosphere Zone 2 and Division 2. C520 is also available as an intrinsically safe version for installation in potentially explosive atmospheres. These devices are labeled with the X symbol – C520X and are approved for use in Zone 0, 1 and 2 and Division 1 and 2.

The C520/C520X is intended for installation in a B connection head or larger according to DIN 43729.

The R520 is an intelligent, universal HART-compatible two-wire rail-mount transmitter for temperature, resistance or voltage measurements in an industrial environment. It is available with a Non-Incendive approval for use in potentially explosive atmosphere Zone 2 and Division 2. The R520 is also available as an intrinsically safe version for installation in potentially explosive atmospheres. These devices are labeled with the X symbol – R520X. and are approved for use in Zone 1 and 2 while the input can be connected to Zone 0. Also Installation in Division 1 is possible.

The R520/R520X is intended for installation on a top-hat rail according to DIN EN 50022.



ATTENTION!

Responsibility for the use of the device with regard to suitability, intended use and area of application lies solely with the user.

The manufacturer shall not be liable for damage resulting from improper use or use for other than the intended purpose.

1.2 Product liability and guarantee

Use of the product for other than the intended purpose or improper installation, and operation may lead to loss of the guarantee. The guarantee shall likewise be void if the device is damaged or its function otherwise impaired.

Inor Process AB hereby guarantees that the product will be free of material and workmanship defects for a period of five (5) years from the date of delivery ("limited guarantee"). This limited guarantee refers to repairs or exchanges, and is only valid for the first end user of the product. The "General conditions of sale" forming the basis of the purchase contract are also applicable.

1.3 Certifications

1.3.1 Certification IPAQ C520X

Control drawing:	88DRW00025
EC: ATEX approval	ITS 09 ATEX 26304X
USA: FM approval (PENDING)	CE 0539  II 1G Ex ia IIC T4 to T6 IS / I / 1, 2 / A-D / T4 to T6; Entity I / 0, 1, 2 / AEx ia IIC T4 to T6; Entity
Canada: CSA approval (PENDING)	IS / I / 1, 2 / A-D / T4 to T6; Entity I / 0, 1, 2 / Ex ia / IIC / T4 to T6; Entity

1.3.2 Certifications IPAQ C520N

Control drawing:	88DRW00025
EC: ATEX approval	ITS 09 ATEX 26305X CE  II 3G Ex nL IIC T4 to T6
USA: FM approval (PENDING)	NI / I, II / 2 / A-G / T4 to T6; Entity I / 2 / AEx nA IIC T4 to T6; Entity
Canada: CSA approval (PENDING)	NI / I, II / 2 / A-G / T4 to T6; Entity I / 2 / Ex nL / IIC / T4 to T6; Entity

1.3.3 Certifications IPAQ R520X

Control drawing:	88DRW00050
EC: ATEX approval	ITS 09 ATEX 26941X CE 0539  II 2(1)G Ex ia IIC T4-T6; Entity
USA: FM approval (PENDING)	IS CL I, DIV 1, Groups A – D; T4 – T6; Entity Class I, Zone 1 & 2, AEx ia IIC T4 – T6; Entity
Canada: CSA approval (PENDING)	Class I, DIV 1, Groups A, B, C & D per Intrinsic Safety CL I, Zone 1 & 2, Ex ia IIC T4-T6; Entity

1.3.4 Certifications IPAQ R520N

Control drawing:	88DRW00050
EC: ATEX approval	ITS 09 ATEX 26946X CE  II 3G Ex nL IIC T4-T6; Entity
USA: FM approval (PENDING)	NI CL I, DIV 2, GP A – D T4 – T6; Entity Class I, Zone 2, AEx nC IIC T4 – T6; Entity
Canada: CSA approval (PENDING)	Class I, Division 2, Groups A – D, T4 – T6; Entity CL I, Zone 2, Ex nL IIC T4-T6; Entity

1.3.5 SIL Certifications

Compliance: Functional safety acc. to IEC 61508
 Safety Integrity Level: SIL 2
 For details, we refer to the separate document: SIL – Safety Manual.

1.3.6 EC directive compliances

The measuring device complies with the statutory requirements of the following EC directives:
 EMC - Directive 2004/108/EC
 ATEX - Directive 94/9/EC

The manufacturer's Declaration of Conformity can be viewed and downloaded from INOR website www.inor.com.
 Select "Download and Documentation".
 Inor Process AB certifies successful testing of the product by applying the CE mark

1.4 Manufacturer's safety instructions

The measuring device has been built and tested in accordance with the current state of the art, and complies with the relevant safety standards. However, dangers may arise from improper use or use for other than the intended purpose. For this reason, observe all of the safety instructions in this document carefully.

1.4.1 Notes about the documentation

In addition to the safety rules and industrial safety regulations in this documentation, national and regional safety rules and industrial safety regulations must also be observed.

1.4.2 Symbol conventions

For greater clarity, the following symbols are used in this documentation:



DANGER!, WARNING!, ATTENTION!, CAUTION!

This symbol indicates general dangers.

All warnings must always be observed. Even partial failure on your part to observe them can lead to serious damage to health, damage to the device or to the user's system components.



DANGER!

This symbol is used to identify dangers when working with electric current.

Work on the device's electrical and electronic components may only be performed by qualified personnel with the appropriate training.



DANGER!

This symbol indicates dangers in areas with potentially explosive atmospheres, for example those which may arise during installation and operation of explosion-proof devices.

Special regulations apply for use in areas with potentially explosive atmospheres; these must always be observed in order to ensure safe use in such areas. Installation, set-up, operation and maintenance of the device may only be performed by qualified persons with training in explosion protection.



Important note!, Note!, Information!

This symbol identifies important notes and information for working with the device.



Legal note!

This symbol identifies references to legal and normative regulations.



Action

This symbol identifies all instructions for actions; the actions must be performed by the user in the specified sequence.



Effect

This symbol identifies all of the important effects of the previous actions.

2.1 General description

The C520/C520X / R520/R520X are intelligent two-wire universal transmitters for measurement with up to two user programmable channels in single, differential, average, minimum or maximum mode.

The C520/C520X / R520/R520X are intended for:

- Temperature measurements with single or dual resistance thermometers
- Temperature measurements with single or dual thermocouples
- Temperature measurements with one resistance thermometers and one thermocouple
- Temperature difference measurements with resistance thermometers
- Measurements with potentiometers
- Voltage measurements in a range -10...1000 mV

To increase reliability and stability of the system, C520/R520 transmitters have dual sensor inputs.

The dual sensor inputs enable new safety features such as sensor redundancy and sensor drift monitoring.

C520S/C520XS/R520S/R520XS are reviewed by exida according to IEC 61508-2 for use in SIL 2 rated Safety Instrumented Systems (SIS). For safety instructions see the safety manual.

The C520 and R520 are the standard versions for use in safe (non-hazardous) areas.

The C520N and R520N are non-incendive versions for use in areas with potentially explosive atmospheres, Zone 2 and Division 2.

The C520X and R520X are Intrinsically Safe versions for use in areas with potentially explosive atmospheres, Zone 0, 1 and 2 and Division 1 and 2.

The C520, C520N and C520X are designed for installation in a B connection head according to DIN 43729 or larger.

The R520, R520N and R520X are designed for installation on a top-hat rail according to DIN 50022 / EN 60715.

The two-wire universal C520/C520X / R520/R520X transmitters are HART® 5 and 6-compatible. Configuration of the C520/R520 transmitters is possible with:

- HART® 5 and 6 protocol via 4...20 mA output circuit
- HART® 5 and 6 handheld terminal
- The graphic user interface DTM
- The third part PC software with a FSK modem for HART® 5 and 6 communication
- PC configuration software ConSoft with PC Configuration Kit - ICON

The PC configuration software ConSoft is used for configuration, display and documentation. The current ConSoft version is available for downloading on our website www.inor.com.

2.2 Identification

The transmitter can be identified by the information in the label, see below.

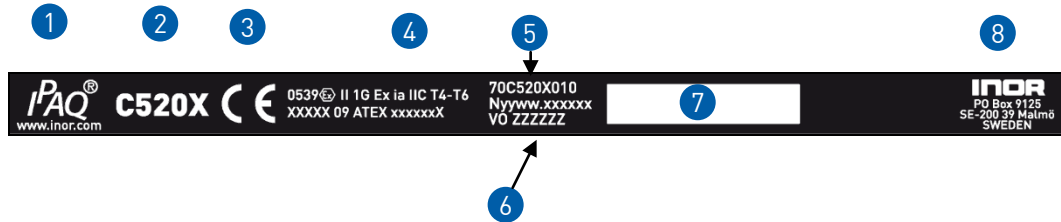

Figure 1: Round label - IPAQ C520X can be used in Category 1, 2 and 3, Zones 0, 1 and 2, Divisions 1 and 2

1	Family name
2	Model name of transmitter
3	CE mark (EC conformity)
4	Technical data (see Chapters 1.3.1, 6.2.3 and 6.2.4 user manual for information)
5	Ordering code (Part No)
6	Serial number and batch number
7	Printable field, sensor configuration
8	Manufacturer of transmitter and address

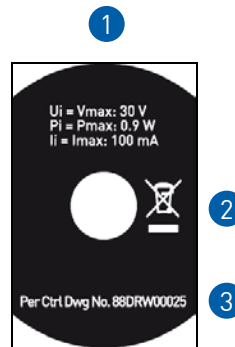
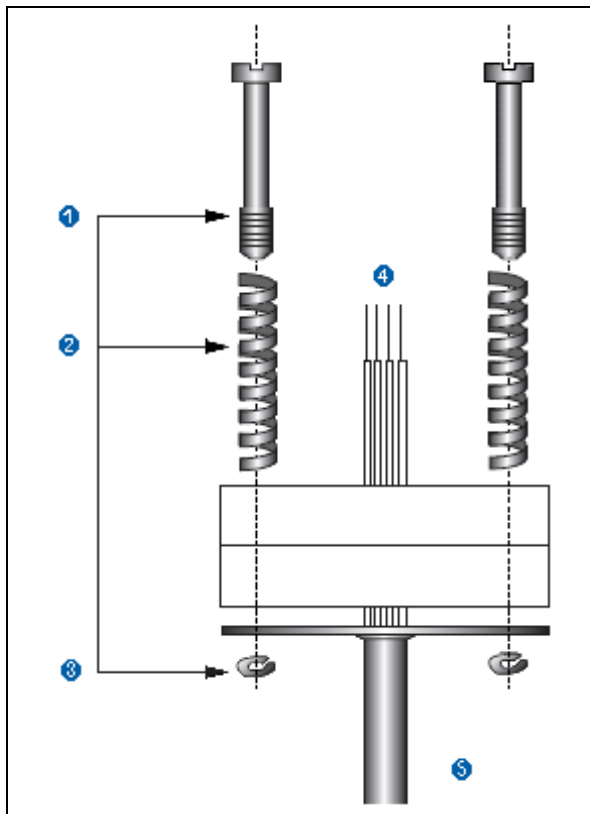

Figure 2: Bottom label - IPAQ C520X

1	Electrical data for output (see Chapter 6.2.3 user manual for information)
2	An electronic/electric device waste marking (see Chapter 7.2 user manual for information)
3	Control drawing number

3.1 Installation of the C520/C520N/C520X

The C520/C520X is intended for installation in DIN B connection heads or larger. The large $\varnothing 7$ mm / 0.28" center hole (see Chapter 6.1.3) facilitates the electrical connection of the measurement sensor and the installation.



1	Screw, M4
2	Spring
3	Lock washer
4	Pt100
5	Protective tube

Figure 3: Connection head installation kit 70ADA00017



ATTENTION!

The C520 transmitter may not be installed in potentially explosive areas other than Zone 2 and Division 2. For Zone 2/Div 2 applications a Class 2 power supply placed in safe area is needed. In other potentially explosive areas, the C520X must be used.

The transmitter C520X must be supplied by an intrinsically safe power supply unit or Zener barrier placed outside of the potentially explosive zone.



ATTENTION!

The C520X transmitter must be installed in a housing with the protection rating IP20 or better according to EN 60529 / IEC 60529.

For Zone 2 applications the C520 must be mounted in an enclosure with at least IP54 according to EN 60529 / IEC 60529.



- **IMPORTANT NOTE!**
- *Ambient temperature considerations*
- *The C520/C520X temperature transmitter has been developed for an ambient temperature range from -40 to 85°C (-40 to +185°F). Please also note that the ambient temperature is also dependent on the temperature category in Section 6.1.5 and 6.2.5, Ex data of the ambient temperature.*

The process temperature is also transferred to the transmitter housing via the protective tube. If the process temperature is close to or exceeds the maximum specified process temperature, then the temperature in the transmitter housing can rise above the maximum permissible ambient temperature. Always check that the ambient temperature where the transmitter is installed is always within the permissible range. One way to decrease heat transfer via the protective tube is to make the protective tube longer or in general to install the transmitter farther away from the heat source. The same safety measures can be taken if the temperature is below the specified minimum temperature.

3.2 Installing the R520/R520N/R520X

The R520 / R520X transmitter is intended for installation on a top-hat rail according to DIN EN 50022.

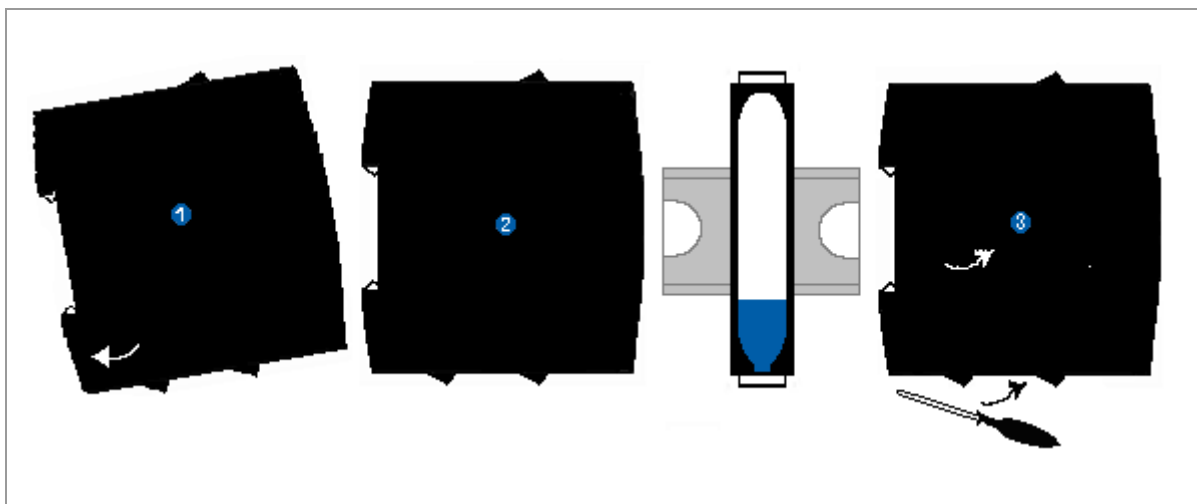

Figure 4: Rail installation

1	Fix the upper part of the transmitter onto the rail.
2	Press the lower part of the transmitter against the rail.
3	To remove the transmitter, use a screwdriver to bend the locking device using a small screwdriver. Carefully pull the transmitter in the forward direction.



ATTENTION!

The R520 transmitter may not be installed in potentially explosive areas other than Zone 2 and Division 2. For Zone 2/Div 2 applications a Class 2 power supply placed in safe area is needed. In other potentially explosive areas, the R520X must be used.

The transmitter R520X can be installed in potentially hazardous area Zone 1 and 2 and the input may be connected to Zone 0. R520X must be supplied by an intrinsically safe power supply unit or Zener barrier placed outside of the potentially explosive zone.

4.1 Safety instructions

**ATTENTION!**

Any work on the device may only be performed by trained and qualified personnel. The regional industrial safety and other safety regulations must always be observed.

**ATTENTION!**

Observe the national regulations for electrical installations!

Any work on the electrical connections may only be performed in the de-energized state.

Observe the voltage specifications on the rating plate!

Observe the relevant installation regulations in your country!

The transmitter is protected against polarity reversal. No damage will occur to the device if the polarity of the supply voltage is switched. The output will then indicate 0 mA.

**ATTENTION!**

When connecting devices with an Ex certificate, the corresponding chapters and the instructions in this manual must be observed.

The transmitter must be supplied with an intrinsically safe power supply unit or Zener barrier outside of the potentially explosive zone.

4.2 C520/C520N/C520X connections

The input and output signals and the power supply must be connected in accordance with the following illustrations. The transmitter is easy to install with the Inor connection head installation kit (see ordering information Chapter 7.1). To avoid measuring errors, all cables must be connected properly and the screws tightened correctly.

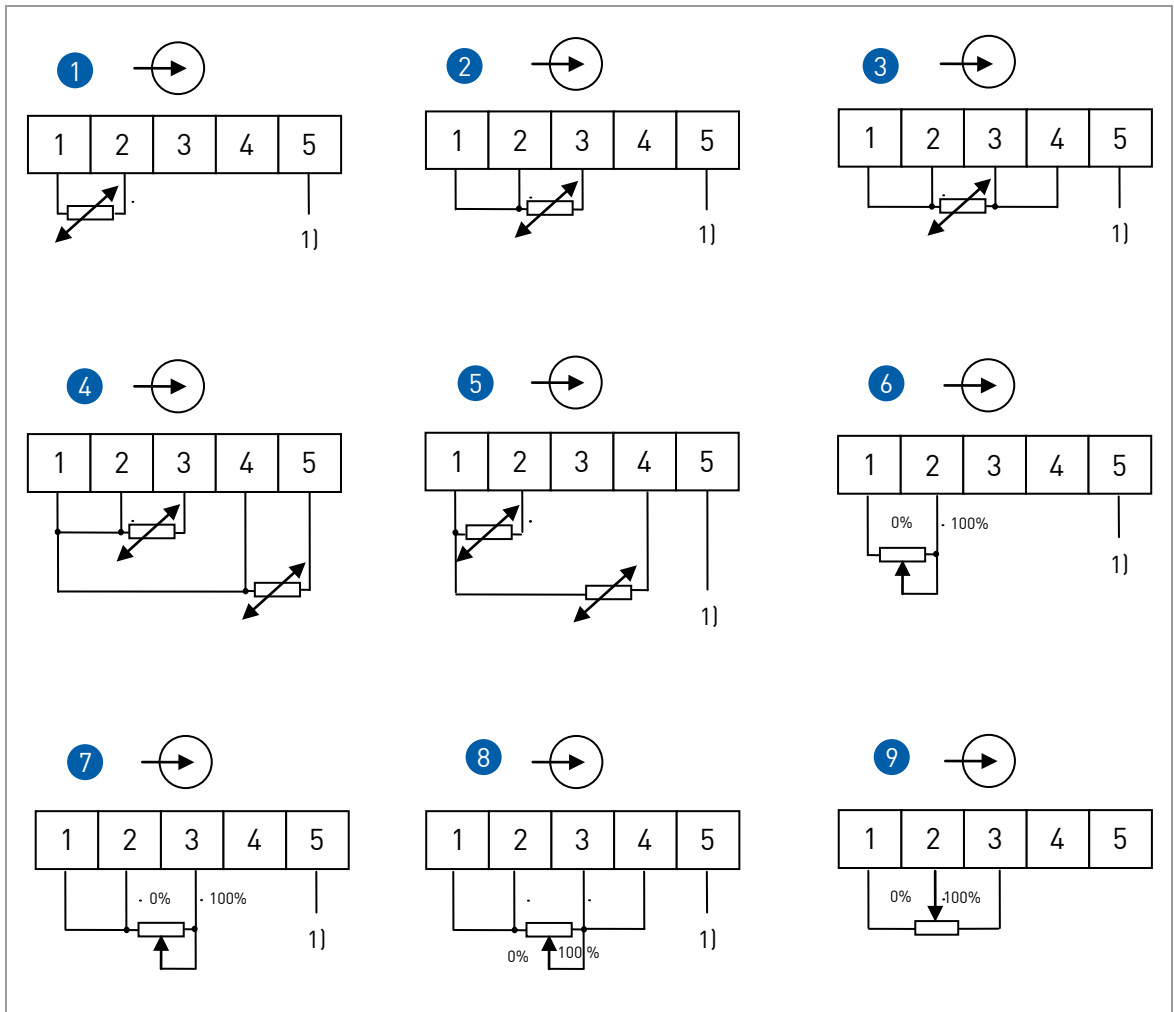

Figure 5: Installation diagram, RTD resistance and potentiometer measurement C520/C520X

1	Pt100...Pt1000, Ni100, Ni120, Cu10 2-wire connection
2	Pt100...Pt1000, Ni100, Ni120, Cu10 3-wire connection
3	Pt100...Pt1000, Ni100, Ni120, Cu10 4-wire connection
4	RTD, redundant sensor elements 2 x 3-wire connection
5	RTD, redundant sensor elements 2 x 2-wire connection
6	Resistance, 2-wire connection
7	Resistance, 3-wire connection
8	Resistance, 4-wire connection
9	Potentiometer, 3-wire connection

1) SmartSense wire

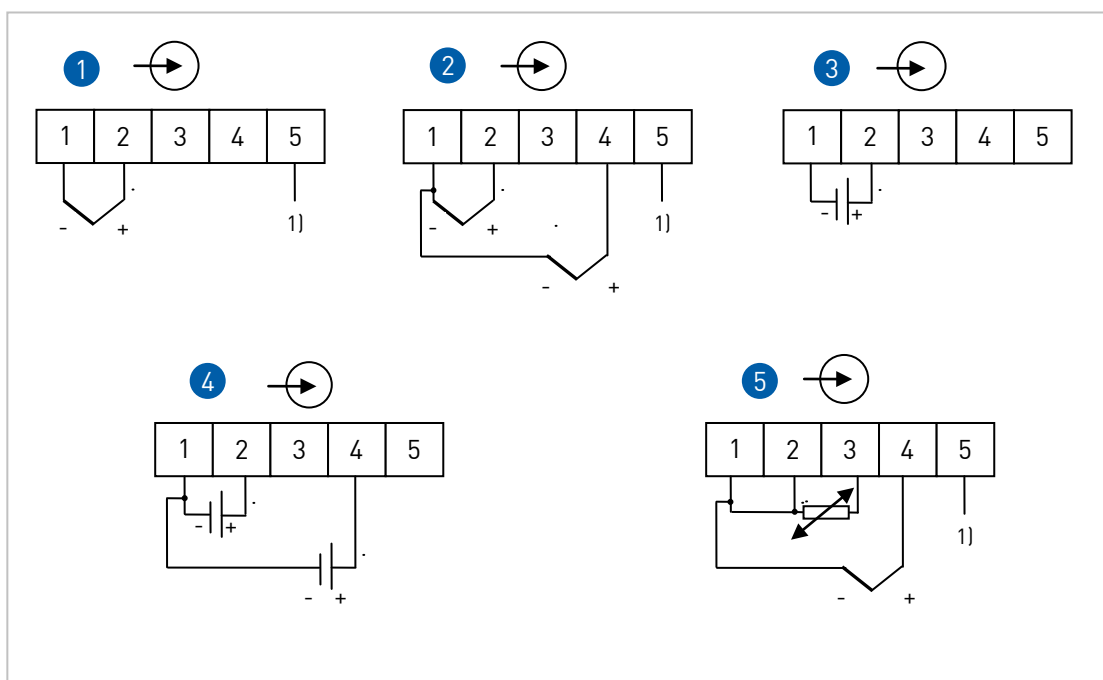

Figure 6: Installation diagram, thermocouple and voltage measurement C520/C520X

1	Thermocouple
2	Thermocouple, redundant sensor elements
3	Voltage
4	Voltage, redundant sensor elements
5	Thermocouple, with remote reference junction compensation

1) SmartSense wire

4.3 Connection diagram C520

**ATTENTION!**

To enable HART communication, the output circuit must have an output load of at least 250 Ω.

**ATTENTION!**

C520 is a Category 3 equipment and the transmitter may not be operated in areas with potentially explosive atmospheres other than Zone 2 and Division 2!

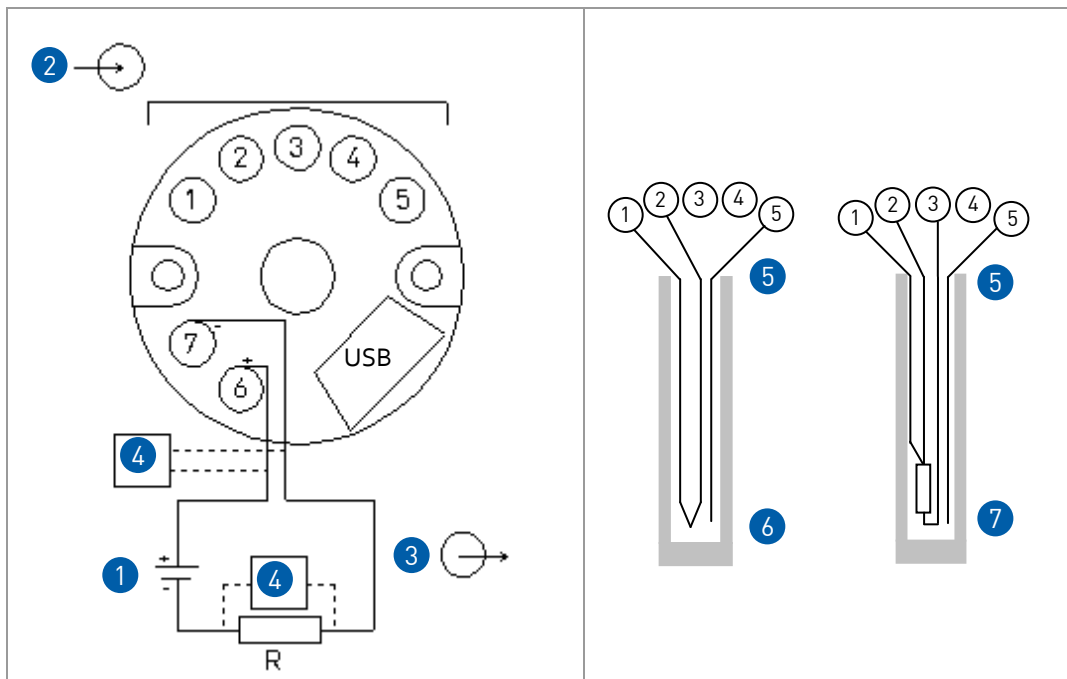

Figure 7: C520 connection

1	Voltage supply 10...36 VDC (terminals 6, 7)
2	Input
3	Output
4	Modem
5	SmartSense temperature sensor
6	Thermocouple
7	Pt100 3 wire connection

**NOTE!**

The HART modem is connected parallel to the output load or parallel to the output of the transmitter (see Figure 7).

**ATTENTION!**

IPAQ C520 may be operated in areas with potentially explosive atmospheres (Zone 2 and Division 2) if the power supply has a protection ensuring that the power supply terminals of the transmitter are limited to transients not exceeding 140% of the rated power supply.

4.4 Connection diagram C520X

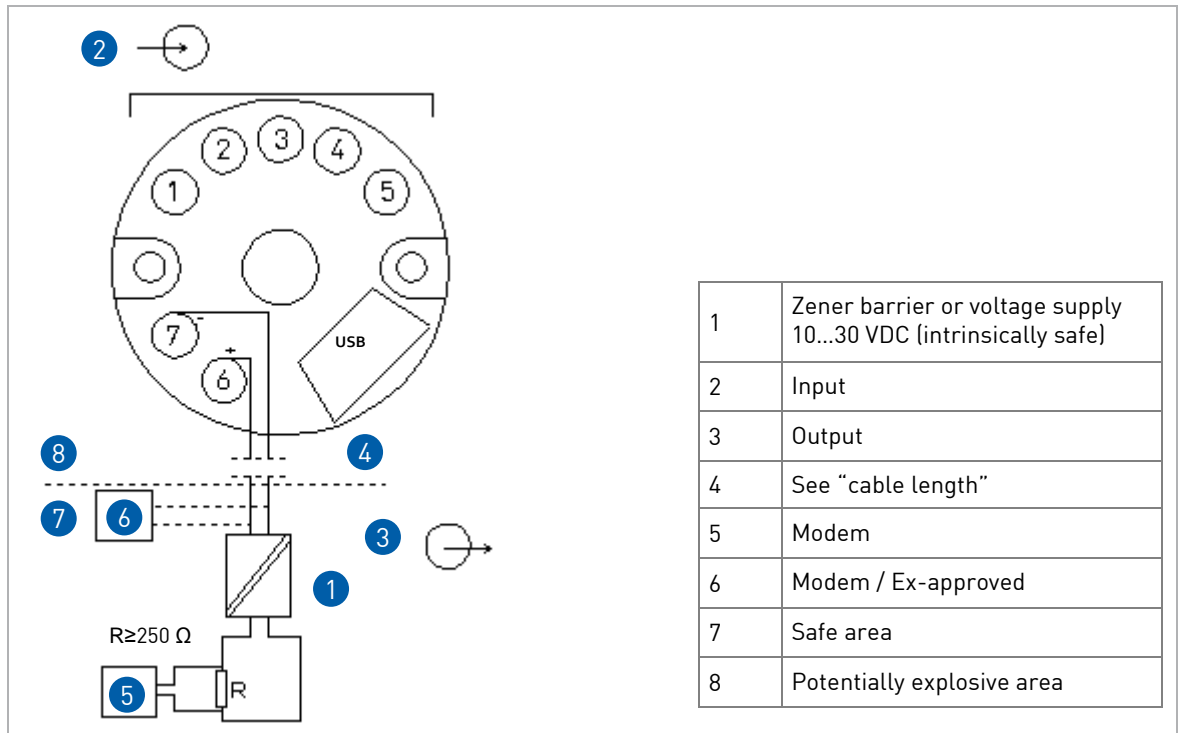

Figure 8: C520X connection

**NOTE!**

The HART modem is connected parallel to the output load or parallel to the output of the transmitter (see Figure 8).

**ATTENTION!**

The transmitter may be operated in areas with potentially explosive atmospheres if the voltage supply is ensured by means of an appropriate power supply unit or a Zener barrier!

**ATTENTION!**

In potentially explosive areas only Ex approved HART modems may be used. The safety instructions for operation in potentially explosive areas must be observed.

**ATTENTION!**

In order to ensure reliable HART communication with C520X, the maximum cable length of the output circuit must be observed (see Chapter 4.8).

4.5 R520/R520N/R520X connections

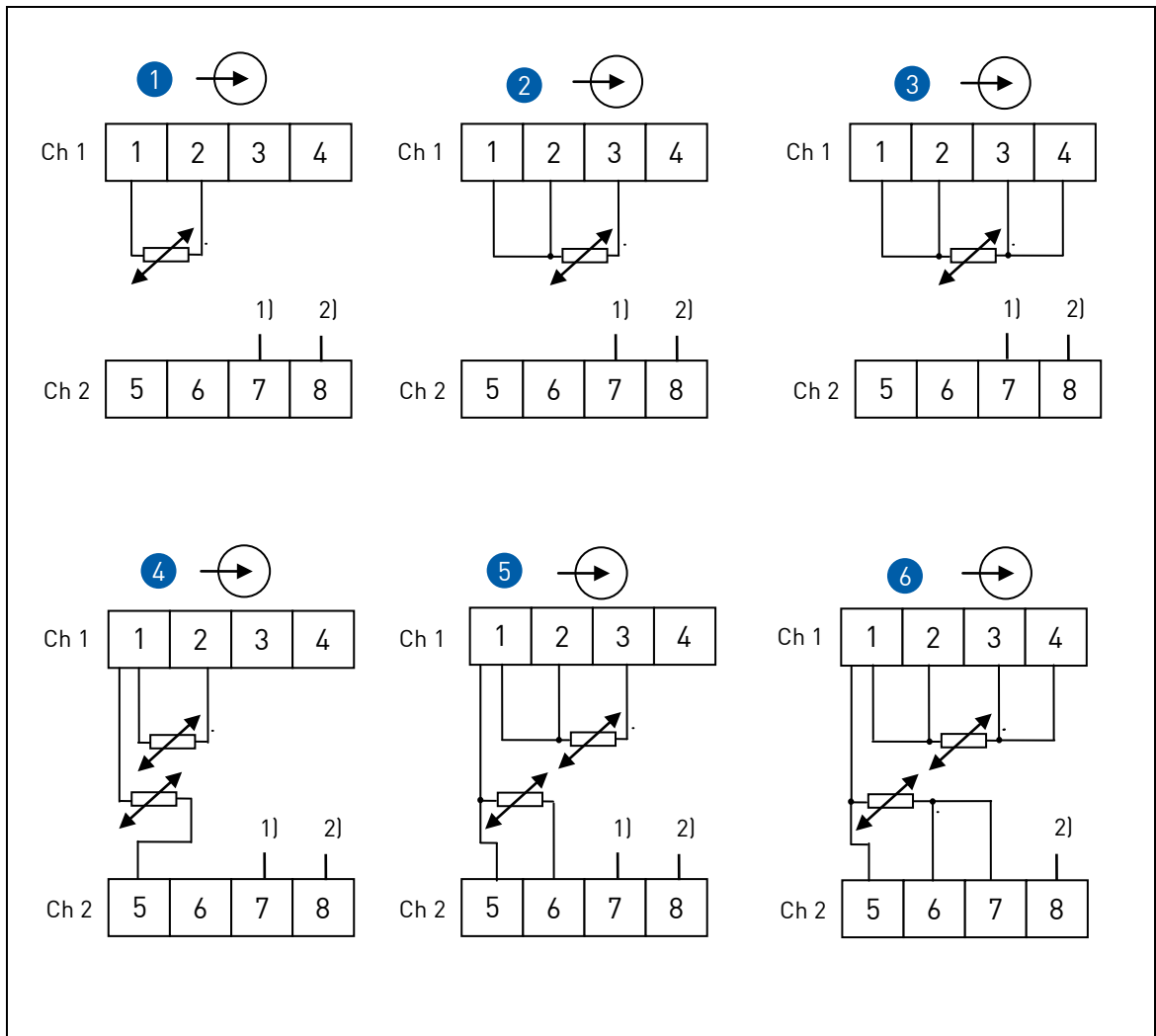

Figure 9: Installation diagram, RTD connections for R520/R520X

- 1) SmartSense wire
- 2) GND (input cable screen)

1	Pt100...Pt1000, Ni100, Ni120, Cu10 2-wire connection Ch 1
2	Pt100...Pt1000, Ni100, Ni120, Cu10 3-wire connection Ch 1
3	Pt100...Pt1000, Ni100, Ni120, Cu10 4-wire connection Ch 1
4	RTD, redundant sensor elements 2 x 3-wire connection Ch 1+ Ch 2
5	RTD, redundant sensor elements 2 x 2-wire connection Ch 1+ Ch 2
6	RTD, redundant sensor elements 2 x 4-wire connection Ch 1+ Ch 2

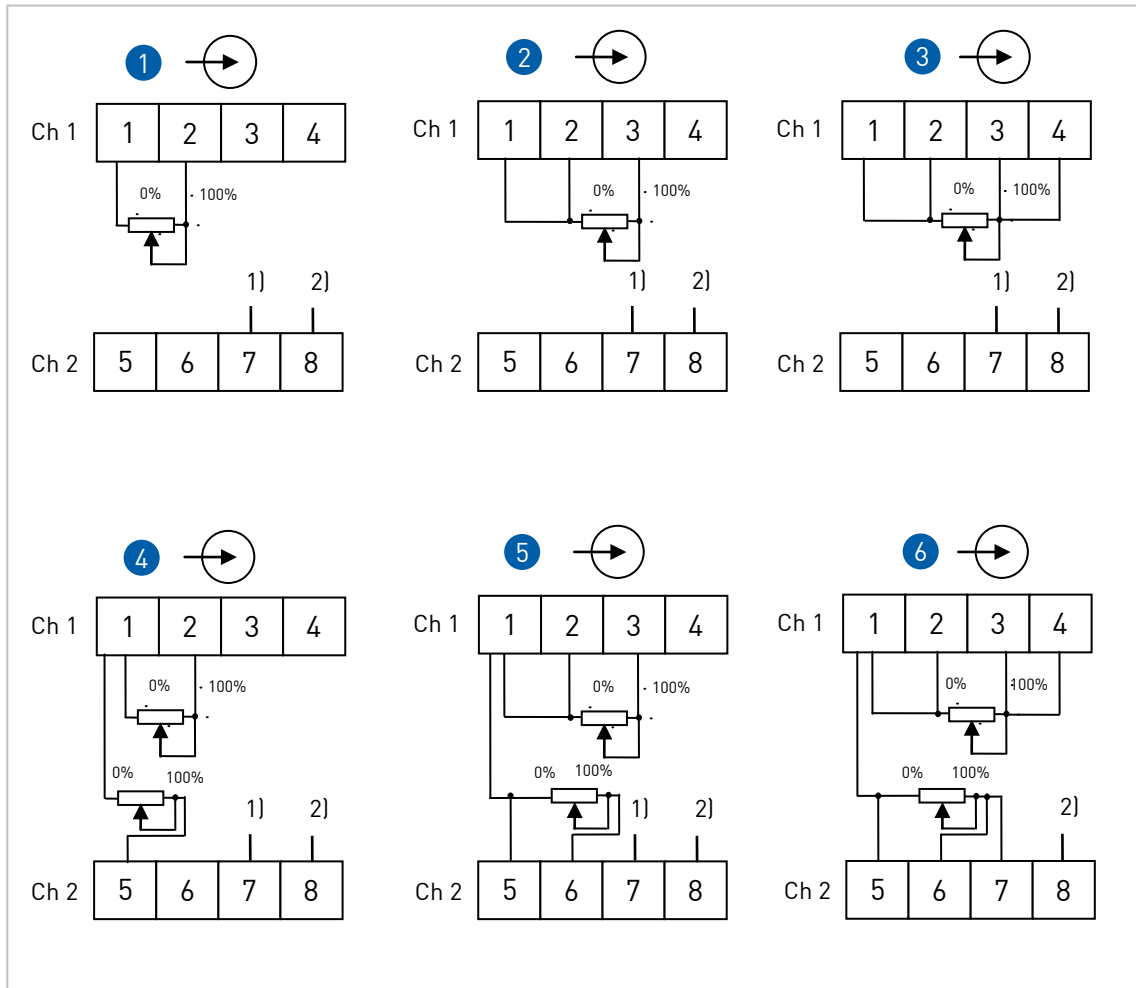

Figure 10: Installation diagram, resistance connections for R520/R520X

- 1) SmartSense wire
- 2) GND (input cable screen)

1	Resistance, 2-wire connection Ch 1
2	Resistance, 3-wire connection Ch 1
3	Resistance, 4-wire connection Ch 1
4	Dual resistance, 2-wire connection on Ch 1 and Ch2
5	Dual resistance, 3-wire connection on Ch 1 and Ch2
6	Dual resistance, 4-wire connection on Ch 1 and Ch2

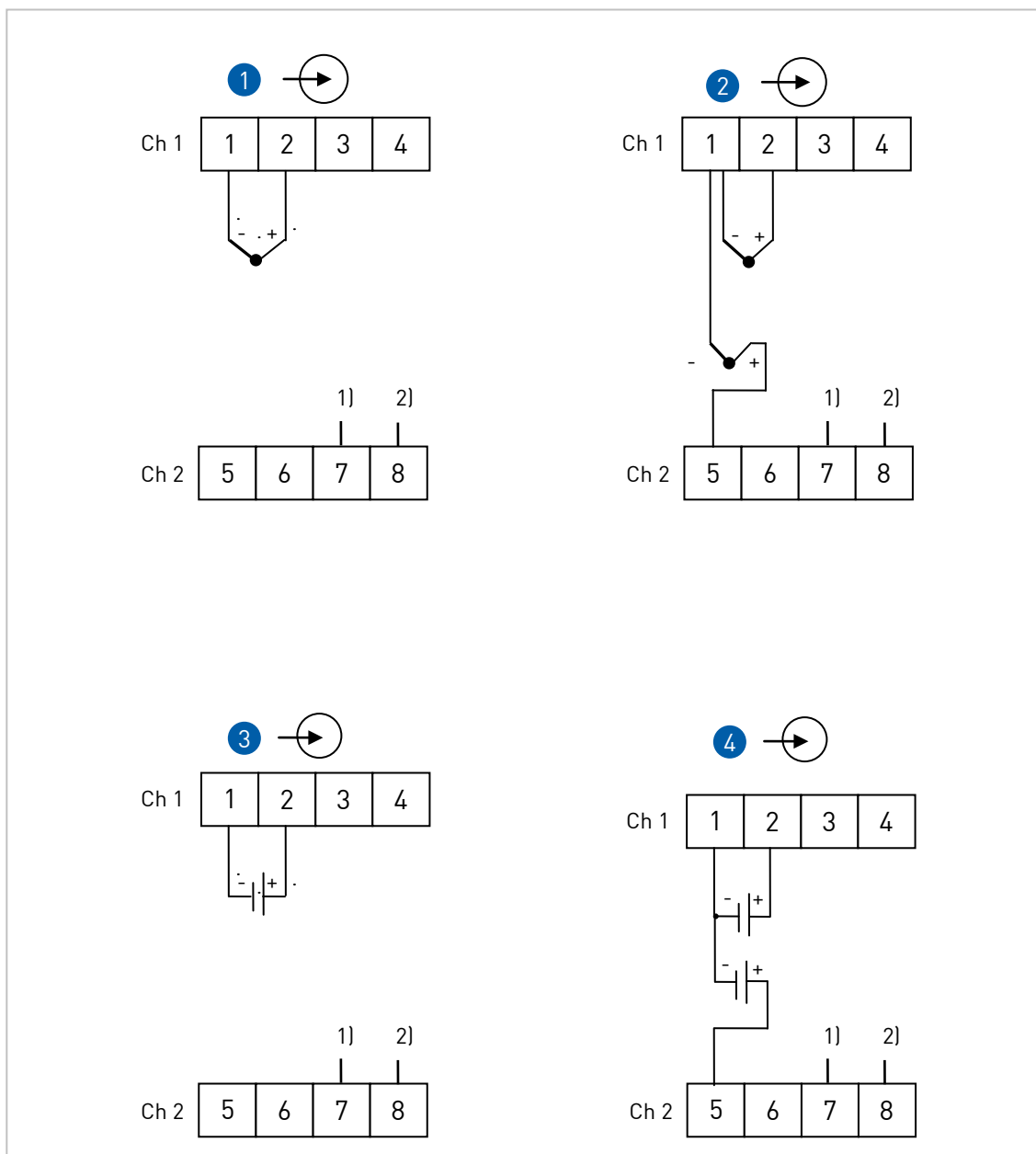

Figure 11: Installation diagram, thermocouple and voltage connections for R520/R520X

- 1) SmartSense wire
- 2) GND (input cable screen)

1	Thermocouple
2	Thermocouple, redundant sensor elements
3	Voltage
4	Voltage, redundant sensor elements

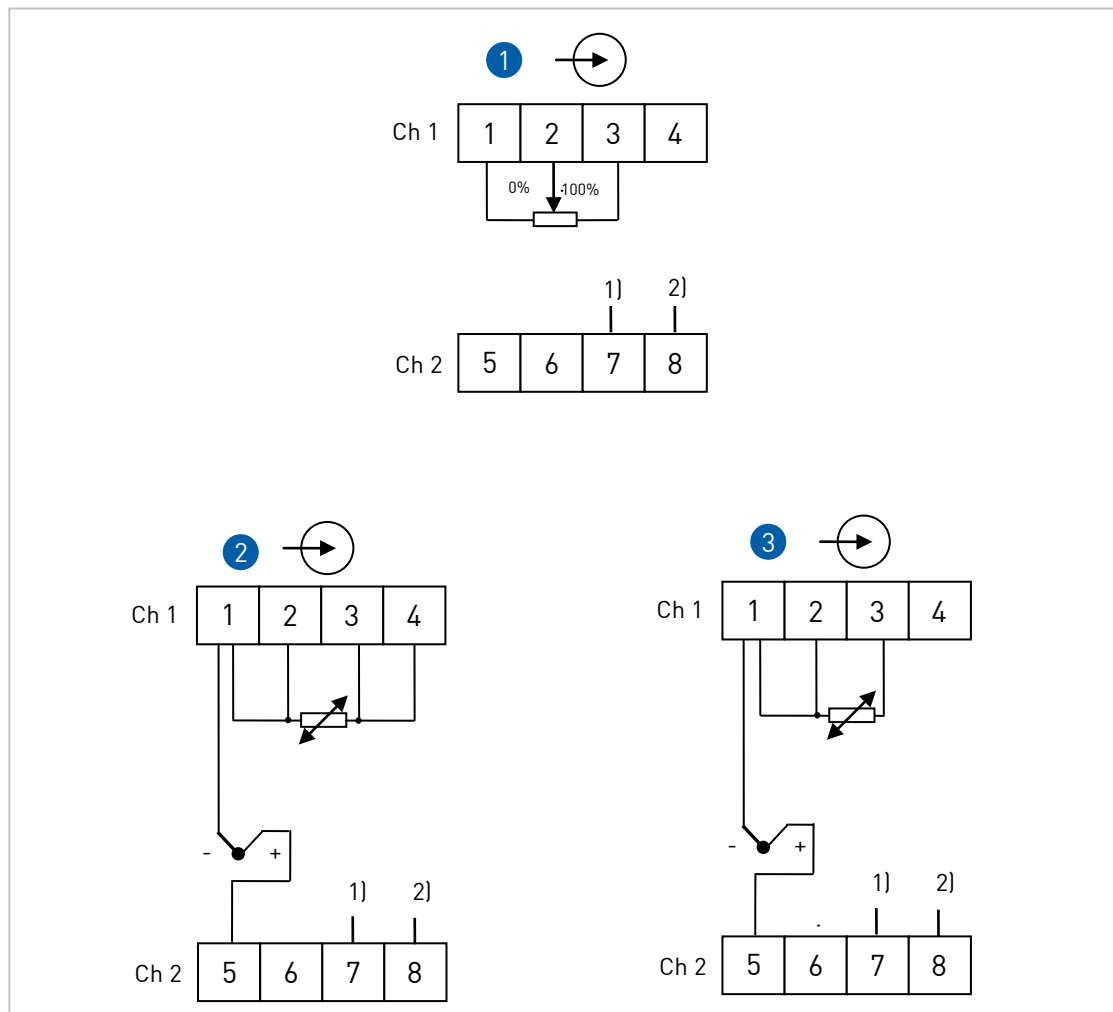

Figure 12: Installation diagram, potentiometer and combined thermocouple and RTD connections for R520/R520X

- 1) SmartSense wire
- 2) GND (input cable screen)

1	Potentiometer 3-wire connection
2	Thermocouple and redundant 4-wire RTD elements
3	Thermocouple with 3-wire RTD elements as external CJC

4.6 Connection diagram, R520

**ATTENTION!**

IPAQ R520 is a Category 3 equipment and may only be installed in an area with a potentially explosive atmosphere Zone 2 / Division 2 or it may be installed in safe area and connected to a sensor located in an area with a potentially explosive atmosphere Zone 2 / Division 2!

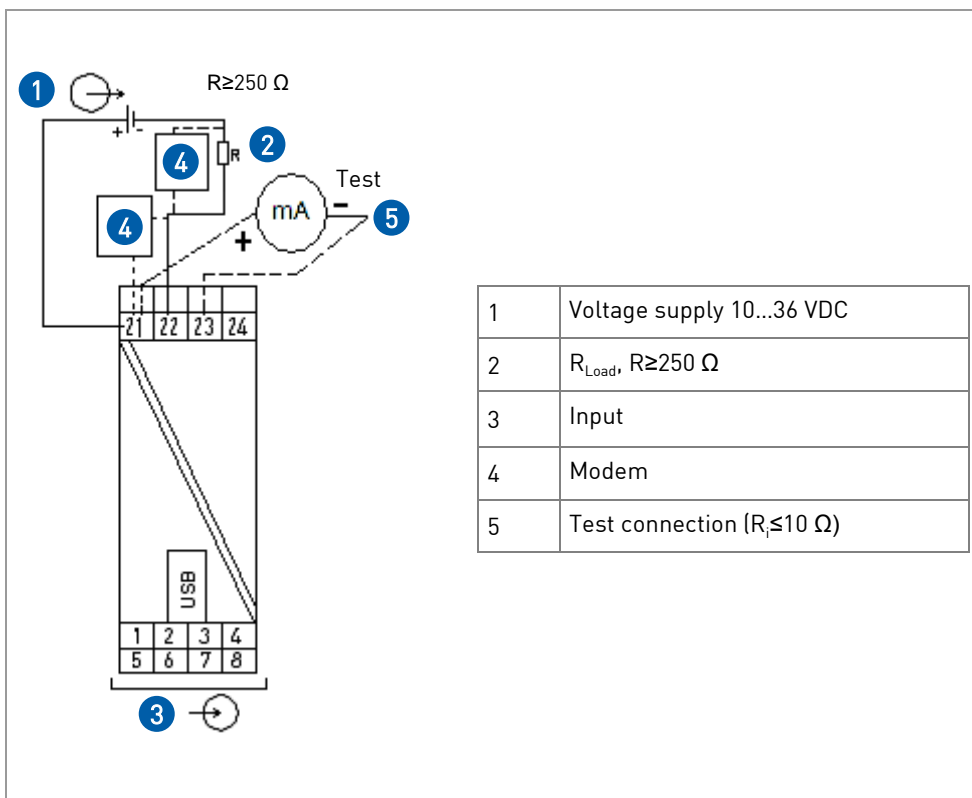

Figure 13: R520 connection diagram

**NOTE!**

The HART modem is connected parallel to the output load or parallel to the output of the transmitter (see Figure 13).

4.7 Connection diagram, R520X

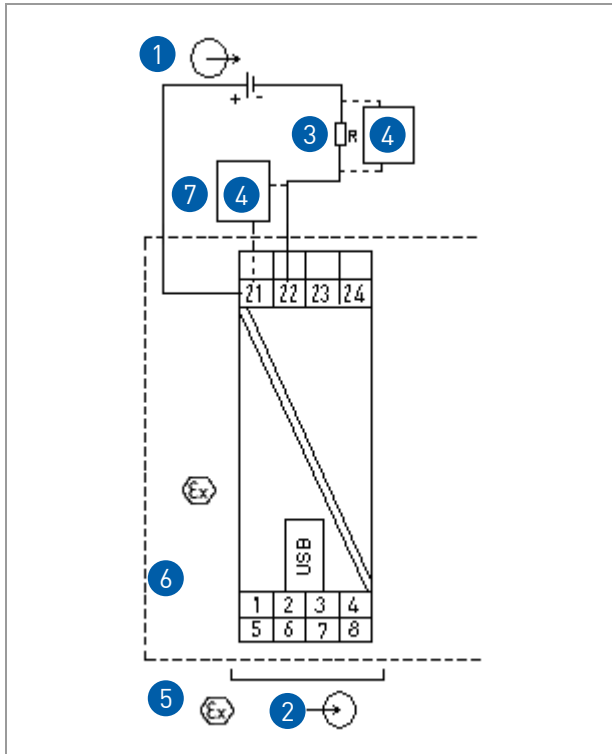

Figure 14: R520X connection diagram

1	Voltage supply 10...30 VDC (intrinsically safe - terminals 21, 22)
2	Input (intrinsically safe)
3	R_{Load} (intrinsically safe)
4	Modem / Ex (intrinsically safe)
5	Classified hazardous area (potentially explosive area e.g. Zone 0, 1 or 2)
6	Classified hazardous area (potentially explosive area e.g. Zone 1 or 2)
7	Safe area

4.8 Cable length

In order to ensure reliable HART communication with C520/R520, the maximum cable length of the output circuit must be observed.

**ATTENTION!**

In the Ex version, please note that the maximum cable length is determined by a resistance, an inductance and a capacitance of the cable. The total capacitance and inductance of the cable must be within the limits for the transmitter described in the Ex certificate.

To calculate the maximum cable length for the output circuit, determine the total resistance of the output loop (load resistance plus the approximate cable resistance). Find out the capacitance of the cable being used. In the tables below you can find the maximum cable length based on the typical values for 1 mm² cables. CN is the abbreviation for Capacitance Number which is multiple of 5000 pF present in the device.

Field device	Cable insulation		
	PVC	Polyethylene	Polyethylene foam
1 (CN = 1)	600 m	1100 m	2000 m
10 multi-drop (CN = 1)	500 m	900 m	1600 m
10 multi-drop (CN = 4,4)	85 m	150 m	250 m

Table 1: Maximum length for typical 1 mm² cables

Insulation	Capacitance
PVC	300...400 pF/m
Polyethylene	150...200 pF/m
Polyethylene foam	75...100 pF/m

Conductors			Resistance (both conductors in serie)
Area	Diameter	AWG	
2.0 mm ²	1.6 mm	14	17 Ω/km
1.3 mm ²	1.3 mm	16	28 Ω/km
1.0 mm ²	1.15 mm	17	36 Ω/km
0.8 mm ²	1.0 mm	18	45 Ω/km
0.5 mm ²	0.8 mm	20	70 Ω/km
0.3 mm ²	0.6 mm	22	110 Ω/km
0.2 mm ²	0.5 mm	24	160 Ω/km

Table 2: Cable parameters

For multiple connections (multi-drop see the Figures 16), the following formula shall be used

$$L = \frac{65 \times 10^6}{R \times C} \times \frac{[Cn \times 5000 + 10000]}{C}$$

L:	Cable length (m)
R:	Load resistance (incl. The resistance of any Zener barrier) + cable resistance (Ω)
C:	Cable capacitance/meter (pF/m)
Cn:	Number of C520/R520 transmitters in the loop

Cable length can be changed to ft. The capacitance has to be specified in pF/ft.

5.1 C520/R520 in HART network

Communication mode supported by C520/R520 transmitters is a master-slave mode.

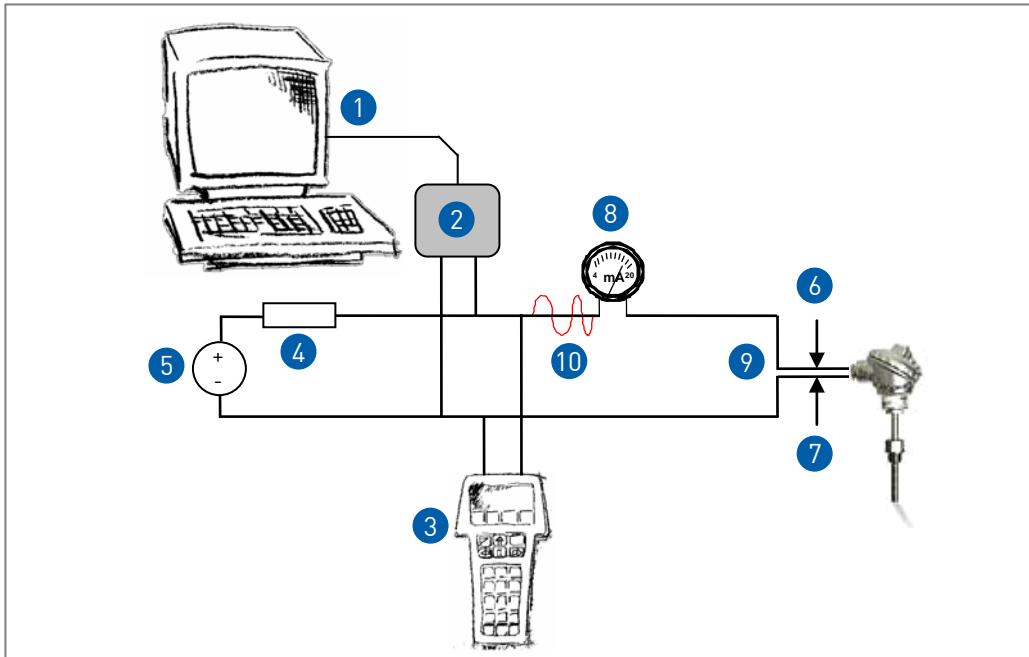

Figure 15: C520 point-to-point analog / digital mode

1	Primary master
2	HART modem
3	Secondary master
4	Load $\geq 250 \Omega$
5	DC power supply
6	Terminal 6
7	Terminal 7
8	Milliamperemeter Load $\geq 250 \Omega$
9	4...20 mA
10	HART

Figure 15 shows a point-to-point connection between the C520/R520 and the HART master equipment. The device's current output may be active or passive.

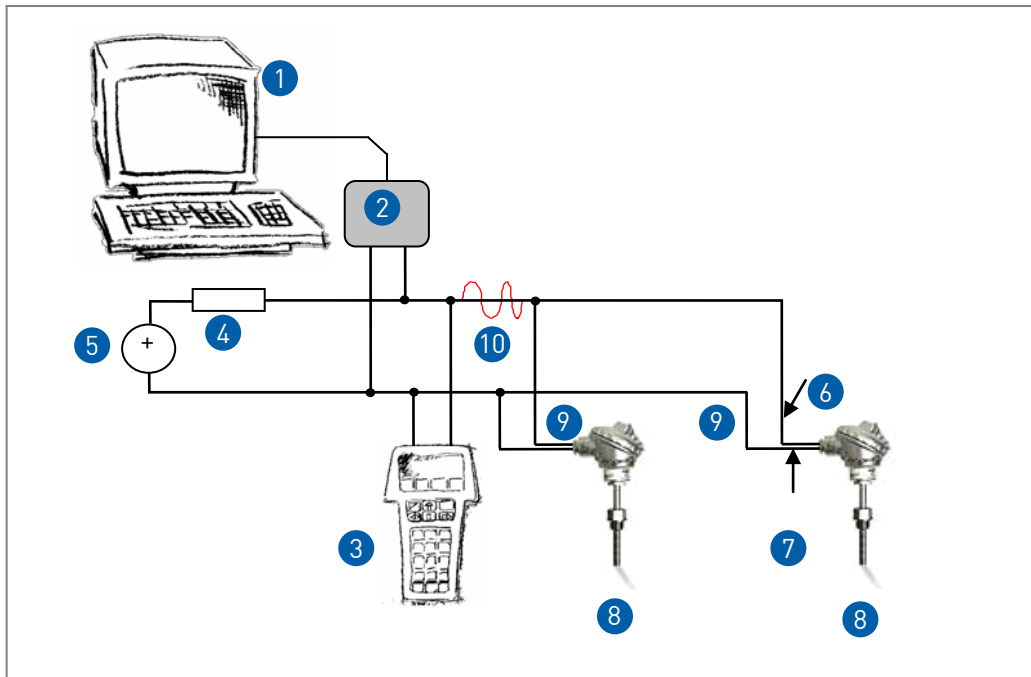

Figure 16: C520 in a multipoint connection (multi-drop mode) with up to 64 devices in parallel

1	Primary master
2	HART modem
3	Secondary master
4	Load $\geq 250 \Omega$
5	DC power supply
6	Terminal 6
7	Terminal 7
8	C520 or R520 loop current mode disabled up to 64 slaves can be connected
9	4 mA
10	HART

Figure 16 shows a multipoint connection (multi-drop) with up to 64 devices (C520/R520 or other HART equipment) in parallel. The device's current outputs must be passive.

Burst mode is not supported.

5.2 Configuration of the C520/C520N/C520X / R520/R520N/R520X



ATTENTION!

Only an Ex approved HART modem located in safe area may be connected to a transmitter placed in potentially explosive area.

In the table below are the factory settings of the C520/C520X / R520/R520X transmitters.

The transmitters are delivered with either a factory settings or configured according to customers' specifications.

Menu	Designation	Parameter	Factory setting
Device Root menu			
-> Sensors	-> Channel 1	Type of sensor 1	RTD Pt100 $\alpha=0.003850$
		Number of wires	4
		PV Lower range value	0
		PV Upper range value	100
		Digital units	°C
		Lock Code	Unlocked
		Damping value	4 s
		Line frequency	55
		Isolation Resistance monitoring	Off
		Sensor Break (Off/Downscale/Upscale)	Upscale
		Sensor Short circuit (Off/Downscale/Upscale)	Upscale
		Sensor Drift (Off/Downscale/Upscale)	Off
	-> Channel 2	Type of sensor 2	None
		Number of wires	
		PV Lower range value	
		PV Upper range value	
		Digital units	°C
		Lock Code	Unlocked
		Damping value	4 s
		Line frequency	55
		Isolation Resistance monitoring	Off
		Sensor Break (Off/Downscale/Upscale)	Off
		Sensor Short circuit (Off/Downscale/Upscale)	Off
		Sensor Drift (Off/Downscale/Upscale)	Off

Table 3: The factory settings for C520/C520X / R520/R520X transmitters

5.3 Configuration alternatives

The 520 series transmitters can be configured by means of:

1. The PC based configuration software ConSoft version 1.2.0.0 or higher and the INOR USB Interface version 1.2.04 or higher, via a USB port on the PC (for more information see the user instructions for the ICON Configuration Kit)
2. A hand held communicator (secondary master) such as the field communicators FC375/FC475 (Emerson)
3. EDD enabled device management softwares/systems (primary master) such as:
 - 1) Smart Device Configurator SDC-625
 - 2) PDM - Process Device Manager (Siemens)
 - 3) AMS - Asset Management Solutions (Emerson)
 - 4) FDM - Field Device Manager (Honeywell)
 - 5) DTM/FDT enabled softwares/systems such as PACTware

5.3.1 Configuration of the 520 series transmitters with ConSoft

ConSoft is a PC based graphical user interface for configuration of all INOR transmitters. The PC configuration software ConSoft is used for configuration, display and documentation. The current software versions of ConSoft and the USB Interface are available for downloading on our website www.inor.com.

To upgrade your USB Interface software to the latest version, use the following flow chart.

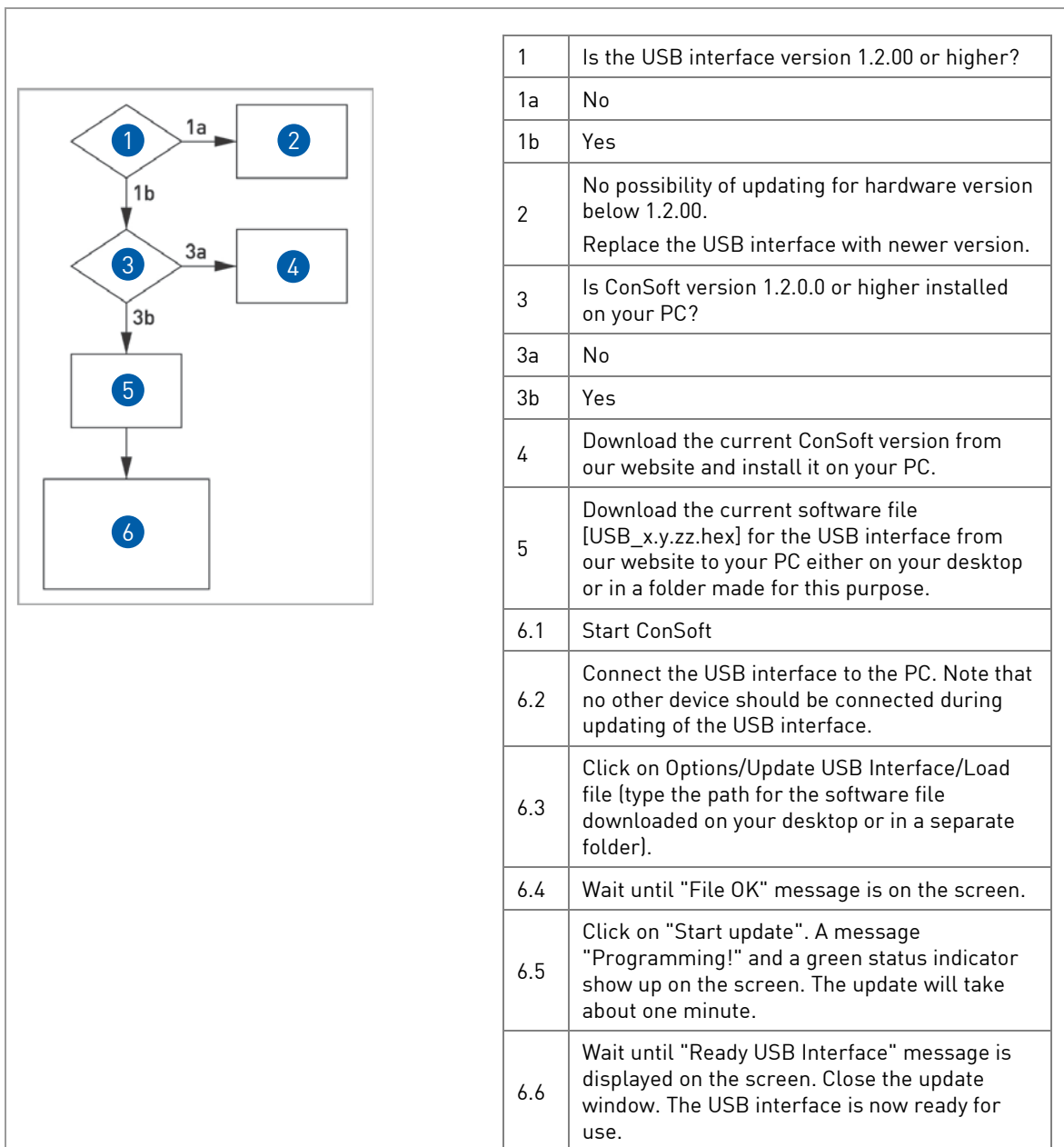

Proper connection of the transmitters with a PC requires an INOR USB Interface (see Figure 17 for connection of the C520/C520X transmitters and figure 18 for connection of the R520/R520X transmitters).



ATTENTION!

Make sure the area is safe before connecting the INOR USB Interface ICON to the transmitter.

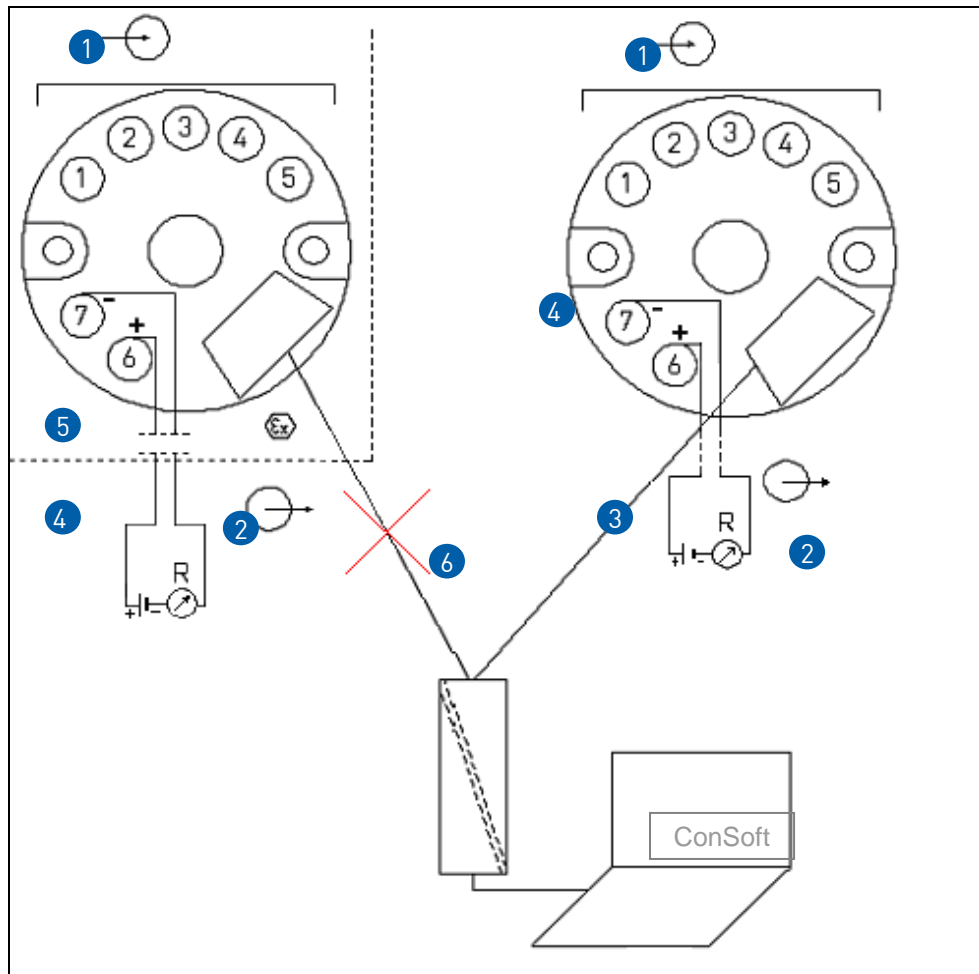

Figure 17: Connection during configuration of C520/C520X

1	Input (intrinsically safe)
2	Output voltage supply (intrinsically safe terminals 6 and 7) and R_{Load} (intrinsically safe)
3	Communication with USB Interface and PC software ConSoft
4	Safe area
5	Classified hazardous area (potentially explosive area e.g. Zone 0, 1 or 2)
6	Connection to USB Interface and PC software ConSoft is not permitted if C520X is placed in the classified hazardous area (potentially explosive area)
7	Connection to the voltage supply during configuration with USB Interface and PC software ConSoft is not needed

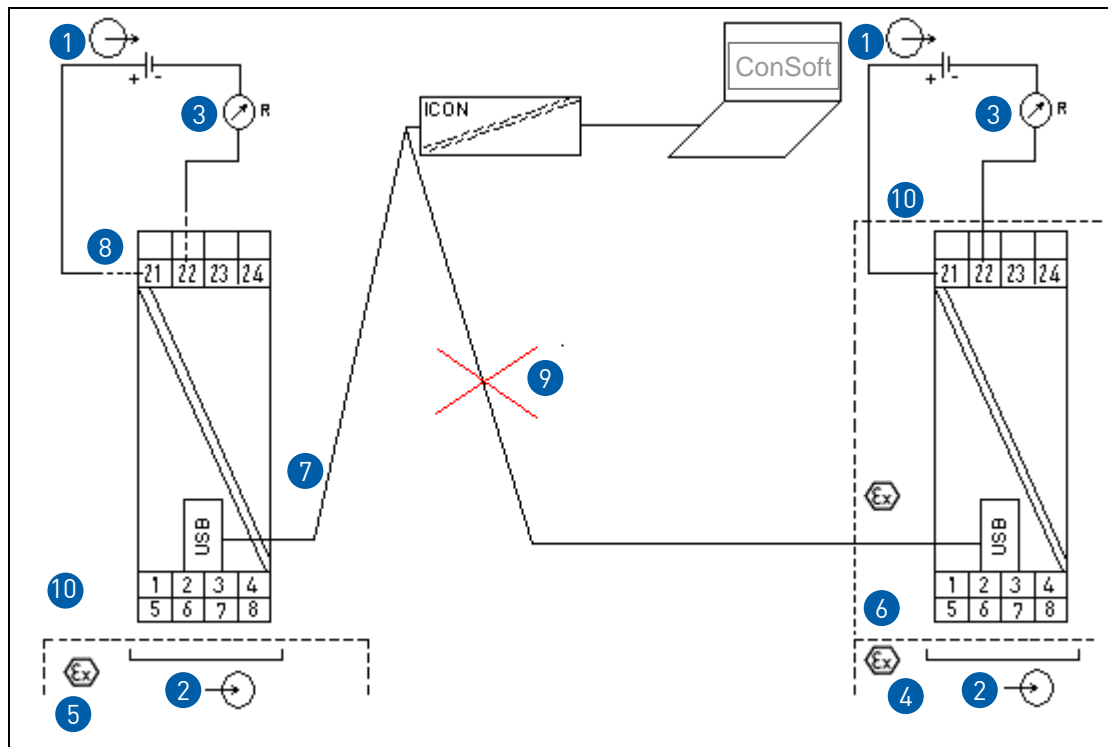

Figure 18: R520X connection to USB Interface and ConSoft during configuration

1	Voltage supply 10...30 VDC (intrinsically safe - terminals 21, 22)
2	Input (intrinsically safe)
3	R_{Load} (intrinsically safe)
4	Classified hazardous area (potentially explosive area e.g. Zone 0)
5	Classified hazardous area (potentially explosive area e.g. Zone 0, 1 or 2)
6	Classified hazardous area (potentially explosive area e.g. Zone 1 or 2)
7	Communication with USB Interface and PC software ConSoft
8	Connection to the voltage supply during configuration with USB Interface and PC software ConSoft is not needed
9	Connection to USB Interface and PC software ConSoft is not permitted if R520X is placed in the classified hazardous area
10	Safe area

5.3.2 Configuration of the 520 series transmitters with handheld communicators FC 375/FC475

The Field communicators FC375/FC475 are handheld communicators from Emerson Process Management for configuring HART and Foundation Fieldbus devices. To be able to configure the transmitters with the FC 375/FC475 you need a Device Description (DD) file. The device driver is possible to download from our website www.inor.com.

The transmitter DD has to be installed on the FC 375/FC475, otherwise the user will work with the transmitter as generic device losing opportunity to control all features of the transmitter. For installing the DD on the FC 375/FC475 the "Easy Upgrade Programming Utility" is needed and the FC375/FC475 must have a system card with "Easy Upgrade" option (see details in the "375/475 Field Communicator User's Manual").

The transmitter DD for FC375/FC475 can also be downloaded from our website. For information about installing, follow the instructions in the attached "readme.txt" file.

For proper connection of transmitters with the handheld communicator - see the Figures 7 and 13 for connection of the C520/R520 transmitters and figures 8 and 14 for connection of the C520X/R520X transmitters.

5.3.3 Device management software's

The 520 series transmitters can be configured via PC software's such as AMS Device Manager or Simatic PDM.

The AMS Device Manager is a PC application from Emerson Process Management for configuring and managing HART and Foundation Fieldbus devices. For adaptation to different devices AMS Device Manager uses Device Descriptions (DD).

The C520/C520X / R520/R520X Device Description has to be installed on the AMS System, and a so called "Installation Kit C520/R520 HART AMS" is needed (available as download on the internet).

For installing of the DD with the Installation Kit refer to the "AMS Intelligent Device Manager Books Online" section "Basic AMS Functionality / Device Configurations / Installing Device Types / Procedures / Install device types from media". Please read also the "readme.txt", which is also contained in the Installation Kit.

The "Installation Kit C520/R520 HART AMS" can also be downloaded from our website www.inor.com. For information about installing, follow the instructions in the attached "readme.txt" file.

AMS supports the EDDL Process Variables Root Menu, the Diagnostic Root Menu and the Device Root Menu for online access to the device.

The Simatic PDM is a PC application from Siemens for configuring HART and PROFIBUS devices. For adaptation to different devices Simatic PDM uses Device Descriptions (DD).

The C520/C520X / R520/R520X Device Description has to be installed on the PDM System, and a so called "Device Install C520/R520 HART PDM" is needed (available as download on the internet).

For installing of the DD on PDM refer to the "PDM Manual" section 13:"Integrating Devices". Please read also the "readme.txt", which is also contained in the Device Install. The transmitter DD for PDM can also be downloaded from our website. For information about installing, follow the instructions in the attached "readme.txt" file.

PDM supports the EDDL Process Variables Root Menu, the Diagnostic Root Menu and the Device Root Menu for online access to the device. Furthermore it supports the Offline Root Menu for offline configuration.

5.3.4 Configuration with PACTware

PACTware is a DTM/FDT enabled PC software, which can be downloaded for free on the Internet.

To be able to configure the transmitters via PACTware, download the transmitter DTM (Device Type Manager) file from our website. For information about installing, follow the instructions in the attached "readme.txt" file.

5.4 Current output and HART dynamic/device variables

The C520/C520X / R520/R520X transmitters handle up to seven measurement-related HART device variables. These variables depend on the device's sensor configuration, and each variable is represented by an output signal of 4...20 mA. See Table 4 for more information.

HART Device Variable	Notes
Channel 1	
Channel 2	
Difference 1-2	valid if both channels are equipped with sensors and of the same type
Difference 2-1	valid if both channels are equipped with sensors and of the same type
Minimum	valid if both channels are equipped with sensors and of the same type
Maximum	valid if both channels are equipped with sensors and of the same type
Average	valid if both channels are equipped with sensors and of the same type

Table 4: The HART dynamic variables for C520/C520X / R520/R520X transmitters

5.5 Diagnostic information according to NAMUR NE 107

Diagnostic information about the connected sensor/sensors and the transmitter is available in the configuration software ConSoft.

The HART diagnostic messages are generated in accordance with NAMUR NE107.

The following are examples of diagnostic information available both in ConSoft and as HART messages:

- Sensor break (failure / sensor wire break on Ch1 or Ch2)
- Sensor short-circuit (failure / sensor wire short-circuit on Ch1 or Ch2)
- Sensor low isolation (failure / low internal isolation in sensor on Ch1 or Ch2)
- Sensor drift (failure / sensor drift between Ch1 and Ch2)
- Sensor backup, automatic switchover from defective sensor (maintenance required / change the sensor on Ch1 or Ch2)
- Transmitter error (failure/transmitter error, non-correctable in the transmitter)

For complete information about all diagnostic information available from the 520 series transmitters, refer to Table 5, 6, 7 and 8 below.

Messages in AMS, PDM, and FC375 device diagnostic			Actions
Standard	NE107 Signal [12]	Error message	Error correction
Transmitter	C	Primary variable out of limits	Check the limits for connected sensor. Replace the sensor allocated to the primary variable.
Transmitter	C	Non-primary variable out of limits	Check the limits for connected sensor. Replace the sensor allocated to the non-primary variable.
Transmitter	C	Primary variable analog output saturated	Check the limits for connected sensor. Ambient temperature is higher then stated limits for sensor, which is allocated to the primary variable analog output. Replace the sensor allocated to the primary variable analog output.
Transmitter	I	Primary variable analog output fixed	Transmitter in multi-drop mode or loop test
Transmitter	C	More status variable	Check device specific errors for more information
Transmitter	I	Cold start	Transmitter is in cold start mode
Transmitter	I	Configuration changed	Information for other softwares.
Transmitter	C	Field device malfunction	Make a self test to find out more. Check even device specific diagnostic. If the error remains replace the device.
Extended device status			
Transmitter	M	Maintenance required	Check Device specific diagnostic for more information about sensors and transmitter.
Transmitter	M	Device variable alert	Check Device specific diagnostic for more information about sensors and transmitter.

Table 5: The HART status messages and diagnostic information for C520/C520X / R520/R520X transmitters

Messages in AMS, PDM, and FC375 device diagnostic		Actions
Device specific	Failure Error message	Error correction
Transmitter	F Sensor break channel 1	Sensor wire broken. Check the sensor and sensor connection on the Channel 1. If error remains replace the sensor connected to Channel 1.
Transmitter	F Sensor break channel 2	Sensor wire broken. Check the sensor and sensor connection on the Channel 2. If error remains replace the sensor connected to channel 2.
Transmitter	F Sensor short circuit channel 1	Sensor wire shorted. Check the sensor and sensor connection on the Channel 1. If error remains replace the sensor connected to Channel 1.
Transmitter	F Sensor short circuit channel 2	Sensor wire shorted. Check the sensor and sensor connection on the Channel 2. If error remains replace the sensor connected to Channel 2.
Transmitter	F Sensor low isolation channel 1	To low isolation in the sensor. Check the sensor by measuring resistance between the wires. If error remains replace the sensor connected to Channel 1.
Transmitter	F Sensor low isolation channel 2	To low isolation in the sensor. Check the sensor by measuring resistance between the wires. If error remains replace the sensor connected to Channel 2.
Transmitter	F Sensor drift	Check the sensors and limits for sensor drift. If error remains replace the faulty sensor.
Transmitter	F System error	Make a self test to find out more, If the error remains replace the device.

Table 6: The HART status messages and diagnostic information for C520/C520X / R520/R520X transmitters

Messages in AMS, PDM, and FC375 device diagnostic		Actions
Device specific	Out of specification Error message	Error correction
Transmitter	S High limit alarm OPM	Check the sensor(s) and sensor connection on both channels. If error remains replace the sensor(s) connected to the transmitter.
Transmitter	S Low limit alarm OPM	Check the sensor(s) and sensor connection on both channels. If error remains replace the sensor(s) connected to the transmitter.
Device specific	Maintenance required Error message	Error correction
Transmitter	M Sensor backup	Transmitter is measuring the working sensor (channel). Replace the faulty sensor.

Table 7: The HART status messages and diagnostic information for C520/C520X / R520/R520X transmitters

Designation	Description
C	Check function
S	Not within specification
M	Maintenance required
F	Failure

Table 8: Explanations acc. to NE107

5.6 Sensor failure monitoring according to NE43

There is possibility of the monitoring of the sensor failure in ConSoft. The difference between the monitoring of the sensor failure in ConSoft and HART is shown in Table 9 below.

ConSoft configuration			HART configuration
Variable name	Possible settings	Factory settings	Comments
Sensor break monitoring	off, downscale (≤ 3.6 mA), upscale (≥ 21 mA) and other value	upscale (≥ 21 mA)	Configuring of the transmitter in ConSoft for other value lower than 21 mA is interpreting as downscale in the transmitter otherwise as upscale during HART configuration.
Sensor short	off, downscale (≤ 3.6 mA), upscale (≥ 21 mA) and other value	upscale (≥ 21 mA)	Configuring of the transmitter in ConSoft for other value lower than 21 mA is interpreting as downscale in the transmitter otherwise as upscale during HART configuration.
Sensor low Isolation	off, downscale (≤ 3.6 mA), upscale (≥ 21 mA) and other value	off	Not permitted for SIL transmitters. Configuring of the transmitter in ConSoft for other value lower than 21 mA is interpreting as downscale in the transmitter otherwise as upscale during HART configuration.

Table 9: The difference between the monitoring of the sensor failure in ConSoft and HART acc. to NE43



NOTE!

Configuring of the sensor failure in ConSoft for other settings that are not according Namur NE43 generates an error message!

5.7 Factory configuration and calibration of the C520/C520X / R520/R520X

The C520/C520X / R520/R520X transmitters are delivered with a factory configuration Pt100 ($\alpha=0.00385$), 4-wire connection, 0...+100°C / +32...+212°F or configured according to customer's requirements (See the Table 3 for detailed information).

Due to the long-term drift of max $\pm 0.01^\circ\text{C}$ or $\pm 0.01\%$ of span per year, a recalibration of the transmitter is normally not needed. Should you for any reason require the recalibration, the transmitter must be returned to the factory.

6.1 C520 specifications

6.1.1 Technical data

Technical data	Designation	Value
Input	Pt100 ($\alpha=0.00385$) IEC 60751	-200...+850°C / -328...+1562°F
	Pt100 ($\alpha=0.003916$) JIS C 1604-81	-200...+850°C / -328...+1562°F
	Pt X ($\alpha=0.00385$) IEC 60751	Corresponding to max. 4000 Ω
Edison curve 7	Ni100 ($\alpha=0.006180$) DIN 43760	-60...+250°C / -76...+482°F
	Ni120 ($\alpha=0.006720$)	-60...+250°C / -76...+482°F
Edison copper winding No.15	Ni1000 ($\alpha=0.006180$) DIN 43760	-50...+180°C / -58...+356°F
	Cu10 ($\alpha=0.004274$)	-50...+200°C / -58...+392°F
	Potentiometer	100...4000 Ω
	Thermocouples	Types: B, C, D, E, J, K, N, R, S, T
	Voltage	-10...1000 mV
	Sensor current	~0.3 mA
	Sensor wire resistance	20 Ω /wire for 2-wire connection 50 Ω /wire for 3/4-wire connection 10000 Ω for thermocouple
	Minimum span	10 Ω / 10°C / 2 mV
Monitoring	Sensor break function	Off, Upscale or downscale ¹⁾
	Sensor short-circuit	Off, Upscale, downscale ¹⁾
	Sensor Drift	Off, Upscale, downscale ¹⁾
Output	Temperature linear for RTD & T/C	4...20 mA, 20...4 mA or customized
	Response time	Single input approx. 300 ms, dual input approx. 600 ms
	Permissible load	635 Ω at 24 VDC incl. 250 Ω loop resistance
Ambient temperature	Operating	See Table 12
Humidity		5...95% RH
Vibrations		Acc. to IEC 68-2-6, Test Fc, 10g
Shock		Acc. to IEC 60068-2-31, test Ec
EMC	Standards	EN 61326-1:2006, EN 61326-3-1:2008, NAMUR NE21:2004
(EMC Directive 2004/108/EC)	Immunity performance	ESD, Radiated EM-field: Criteria A Surge: ~0.5% of span
Galvanic isolation		1500 VAC, 1 min
Power supply	C520	10...36 VDC, polarity protected
Typical accuracy	For more information see RTD and T/C accuracy table 22	$\pm 0.1^\circ\text{C}$ / $\pm 0.2^\circ\text{F}$
Connection head		DIN B or larger

¹⁾ Upscale (≥ 21.0 mA) or downscale (≤ 3.6 mA)

Table 10: C520 specifications

6.1.2 Output load diagram

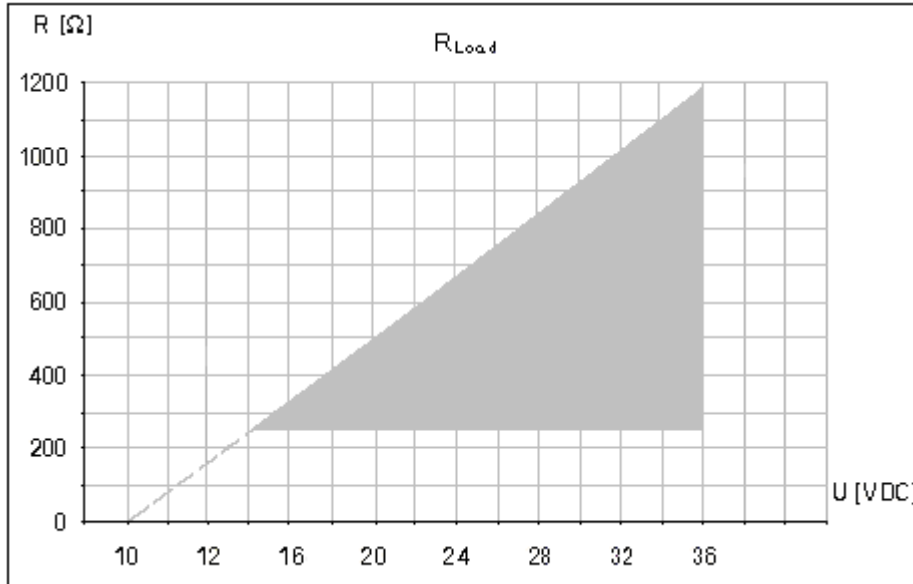

Figure 19: C520 output load diagram

Formula for the maximum permissible output load: C520 permissible $R_{Load} (\Omega) = (U-10)/0.022$

R	Total output load [Ω]
U	Power supply [VDC]

6.1.3 Dimensions

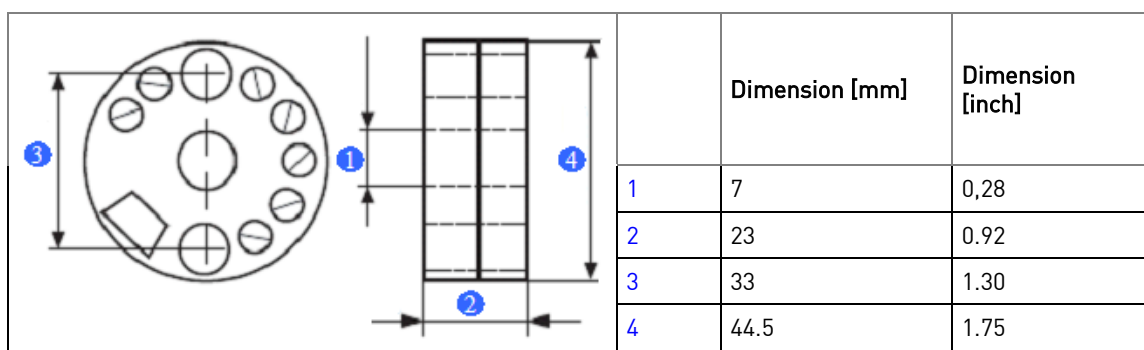

Figure 20: C520 dimensions

6.1.4 Output and input data



Output terminals 6, 7		Input terminals 1, 2, 3, 4, 5	
$U_i = V_{\max}$:	≤ 36 VDC	$U_o = U_{oc}$:	≤ 3.3 VDC
$I_i = I_{\max}$:	-	$I_o = I_{sc}$:	≤ 1.8 mA
$P_i = P_{\max}$:	-	P_o :	≤ 1.5 mW
L_i :	10 μ H	L_o :	25 mH
C_i :	12.1 nF	C_o :	50 μ F

Table 11: Output and input data, C520N

6.1.5 Ambient temperature data for areas with potentially explosive atmospheres



Temperature class	Ambient temperature
T6	$-40^{\circ}\text{C} \leq T_a \leq +65^{\circ}\text{C} / 40^{\circ}\text{F} \leq T_a \leq +149^{\circ}\text{F}$
T5	$-40^{\circ}\text{C} \leq T_a \leq +80^{\circ}\text{C} / 40^{\circ}\text{F} \leq T_a \leq +176^{\circ}\text{F}$
T4	$-40^{\circ}\text{C} \leq T_a \leq +85^{\circ}\text{C} / -40^{\circ}\text{F} \leq T_a \leq +185^{\circ}\text{F}$

Table 12: Ambient temperature data, C520N

6.2 C520X specifications

6.2.1 Technical data

Technical data	Designation	Value
Input	Pt100 ($\alpha=0.00385$) IEC 60751	-200...+850°C / -328...+1562°F
	Pt100 ($\alpha=0.003916$) JIS C 1604-81	-200...+850°C / -328...+1562°F
	Pt X ($\alpha=0.00385$) IEC 60751	Corresponding to max. 4000 Ω
	Ni100 ($\alpha=0.006180$) DIN 43760	-60...+250°C / -76...+482°F
Edison curve 7	Ni120 ($\alpha=0.006720$)	-60...+250°C / -76...+482°F
	Ni1000 ($\alpha=0.006180$) DIN 43760	-50...+180°C / -58...+356°F
Edison copper winding No.15	Cu10 ($\alpha=0.004274$)	-50...+200°C / -58...+392°F
	Potentiometer	100...4000 Ω
	Thermocouples	Types: B, C, D, E, J, K, N, R, S, T
	Voltage	-10...1000 mV
	Sensor current	~0.3 mA
	Sensor wire resistance	20 Ω /wire for 2-wire connection 50 Ω /wire for 3/4-wire connection 10000 Ω for thermocouple
	Minimum span	10 Ω / 10°C / 2 mV
Monitoring	Sensor break function	Off, upscale or downscale ¹⁾
	Sensor short-circuit	Off, upscale, downscale ¹⁾
	Sensor drift	Off, upscale, downscale ¹⁾
Output	Temperature linear for RTD & T/C	4...20 mA, 20...4 mA or customized
	Response time	Single input approx. 300 ms, dual input approx. 600 ms
	Permissible load	635 Ω at 24 VDC incl. 250 Ω loop resistance
Ambient temperature	Operating	See Table 15
Humidity		5...95% RH
Vibrations		Acc. to IEC 68-2-6, Test Fc, 10g
Shock		Acc. to IEC 60068-2-31, test Ec
EMC	Standards	EN 61326-1:2006, EN 61326-3-1:2008, NAMUR NE21:2004
(EMC Directive 2004/108/EC)	Immunity performance	ESD, Radiated EM-field: Criteria A Surge: ~0.5% of span
Galvanic isolation		1500 VAC, 1 min
Power supply	C520X	10 ... 30 VDC, polarity protected
Typical accuracy	For more information see RTD and T/C accuracy table 22	$\pm 0.1^\circ\text{C}$ / $\pm 0.2^\circ\text{F}$
Connection head		DIN B or larger

1) Upscale (≥ 21.0 mA) or downscale (≤ 3.6 mA)

Table 13: C520 X specifications

6.2.2 Output load diagram

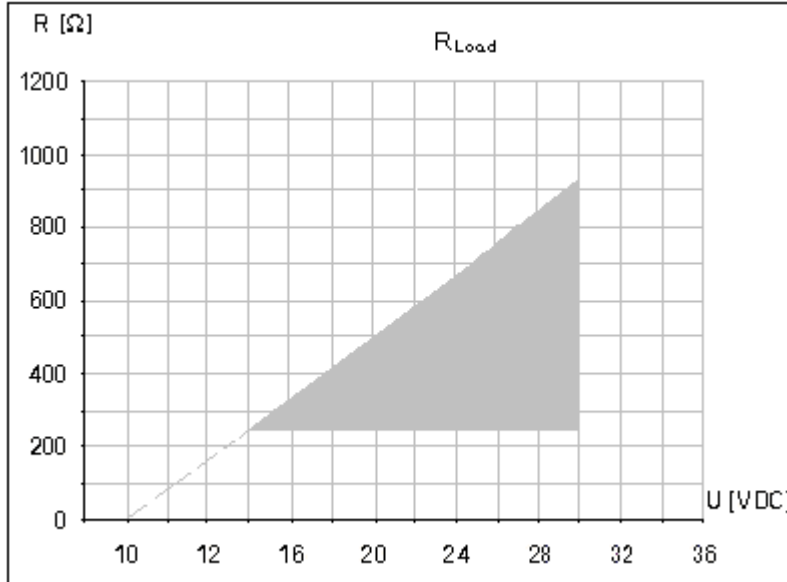

Figure 21: C520X output load diagram

Formula for the maximum permissible output load: C520X permissible $R_{Load} (\Omega) = (U-10)/0.022$

R_{Load}	Total output load [Ω]
U	Power supply [VDC]

6.2.3 Dimensions

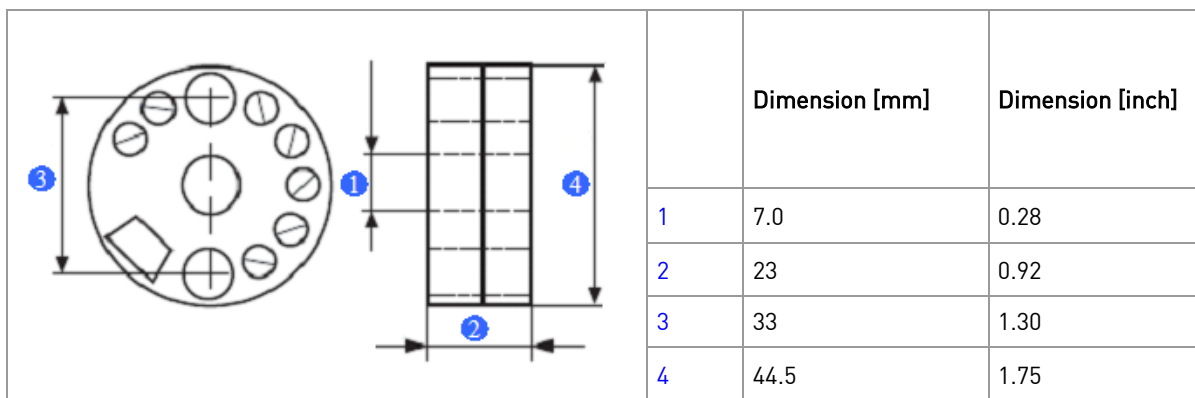

Figure 22: C520X dimensions

6.2.4 Output and input data



Output terminals 6, 7		Input terminals 1, 2, 3, 4, 5	
$U_i = V_{\max}$:	≤ 30 VDC	$U_o = V_{oc}$:	≤ 6.6 VDC
$I_i = I_{\max}$:	≤ 100 mA	$I_o = I_{sc}$:	≤ 26.4 mA
$P_i = P_{\max}$:	≤ 900 mW	P_o :	≤ 46 mW
L_i :	10 μ H	L_o :	25 mH
C_i :	12.1 nF	C_o :	11 μ F

Table 14: Electrical data for outputs-inputs of C520X

6.2.5 Ambient temperature data for areas with potentially explosive atmospheres



Temperature class	Ambient temperature
T6	$-40^{\circ}\text{C} \leq T_a \leq +60^{\circ}\text{C}$ / $40^{\circ}\text{F} \leq T_a \leq +140^{\circ}\text{F}$
T5	$-40^{\circ}\text{C} \leq T_a \leq +75^{\circ}\text{C}$ / $40^{\circ}\text{F} \leq T_a \leq +167^{\circ}\text{F}$
T4	$-40^{\circ}\text{C} \leq T_a \leq +85^{\circ}\text{C}$ / $40^{\circ}\text{F} \leq T_a \leq +185^{\circ}\text{F}$

Table 15: C520X temperature data

6.3 R520 specifications

6.3.1 Technical data

Technical data	Designation	Value
Input	Pt100 ($\alpha=0.00385$) IEC 60751	-200...+850°C / -328...+1562°F
	Pt100 ($\alpha=0.003916$) JIS C 1604-81	-200...+850°C / -328...+1562°F
	Pt X ($\alpha=0.00385$) IEC 60751	Corresponding to max. 4000 Ω
	Ni100 ($\alpha=0.006180$) DIN 43760	-60...+250°C / -76...+482°F
Edison curve No.7	Ni120 ($\alpha=0.006720$)	-60...+250°C / -76...+482 °F
	Ni1000 ($\alpha=0.006180$) DIN 43760	-50...+180°C / -58...+356°F
Edison copper winding No.15	Cu10 ($\alpha=0.004274$)	-50...+200°C / -58...+392°F
	Potentiometer	100...4000 Ω
	Thermocouples	Types: B, C, D, E, J, K, N, R, S, T
	Voltage	-10...1000 mV
	Sensor current	~0.3 mA
	Sensor wire resistance	20 Ω /wire for 2-wire connection 50 Ω /wire for 3/4-wire connection 10000 Ω for thermocouple
	Minimum span	10 Ω
Monitoring	Sensor break function	Off, upscale or downscale ¹⁾
	Sensor short-circuit	Off, upscale, downscale ¹⁾
	Sensor drift	Off, upscale, downscale ¹⁾
Output	Temperature linear for RTD & T/C	4...20 mA, 20...4 mA or customized
	Response time	Single input approx. 300 ms, dual input approx. 600 ms
	Permissible load	635 Ω at 24 VDC incl. 250 Ω loop resistance
Ambient temperature	Operating	See Table 18
Humidity		5...95% RH
Vibrations		Acc. to IEC 68-2-6, Test Fc, 10g
Shock		Acc. to IEC 60068-2-31, test Ec
EMC	Standards	EN 61326-1:2006, EN 61326-3-1:2008, NAMUR NE21:2004
(EMC Directive 2004/108/EC)	Immunity performance	ESD, Radiated EM-field: Criteria A Surge: ~0.5% of span
Galvanic isolation		1500 VAC, 1 min
Power supply	R520	10...36 VDC, polarity protected
Typical accuracy	For more information see RTD and T/C accuracy table 22	$\pm 0.1^\circ\text{C}$ / $\pm 0.2^\circ\text{F}$
Mounting		DIN rail EN 50022

¹⁾ Upscale (≥ 21.0 mA) or downscale (≤ 3.6 mA)

Table 16: R520 specifications

6.3.2 Output load diagram

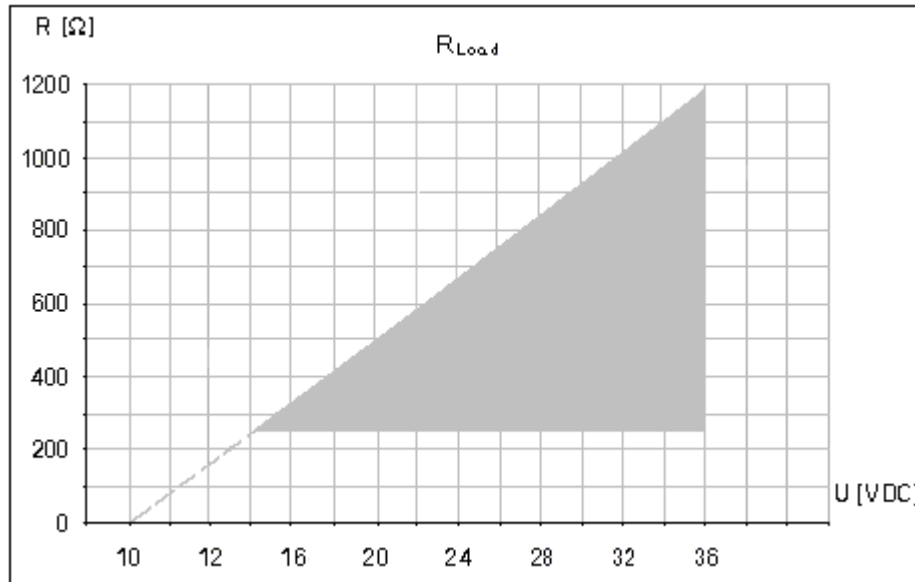

Figure 23: R520 output load diagram

Formula for the maximum permissible output load: R520 permissible $R_{Load} (\Omega) = (U-10)/0.022$

R	Total output load [Ω]
U	Power supply [VDC]

6.3.3 Dimensions

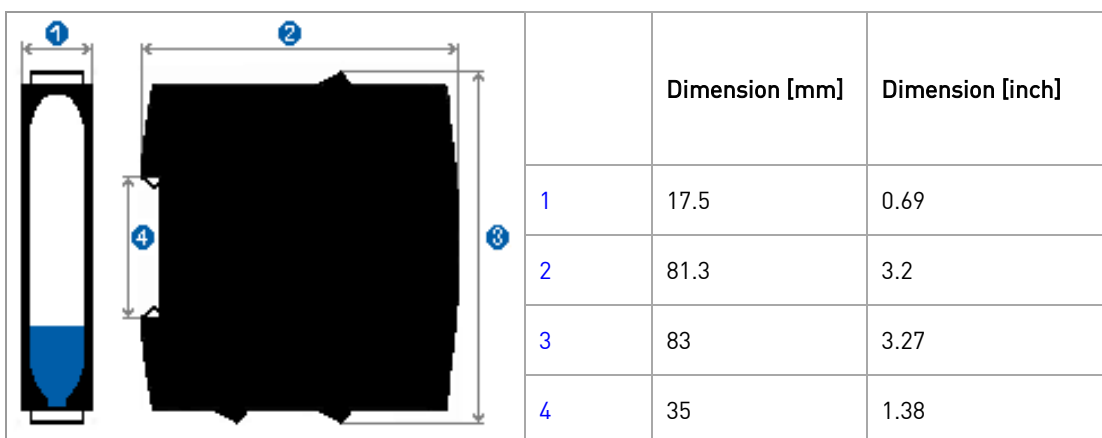

Figure 24: R520 dimensions

6.3.4 Output and input data



Output terminals 21, 22		Input terminals 1 to 8	
$U_i = V_{max}$:	≤ 36 VDC	$U_o = U_{oc}$:	≤ 3.3 VDC
$I_i = I_{max}$:	-	$I_o = I_{sc}$:	≤ 1.8 mA
$P_i = P_{max}$:	-	P_o :	≤ 1.5 mW
L_i :	10 μ H	L_o :	25 mH
C_i :	12.1 nF	C_o :	50 μ F

Table 17: Output and input data, R520N

6.3.5 Ambient temperature data for areas with potentially explosive atmospheres



Temperature class	Ambient temperature
T6	$-20^{\circ}\text{C} \leq T_a \leq +65^{\circ}\text{C}$ / $-4^{\circ}\text{F} \leq T_a \leq +149^{\circ}\text{F}$
T5	$-20^{\circ}\text{C} \leq T_a \leq +70^{\circ}\text{C}$ / $-4^{\circ}\text{F} \leq T_a \leq +158^{\circ}\text{F}$
T4	$-20^{\circ}\text{C} \leq T_a \leq +70^{\circ}\text{C}$ / $-4^{\circ}\text{F} \leq T_a \leq +158^{\circ}\text{F}$

Table 18: Ambient temperature data, R520N

6.4 R520X specifications

6.4.1 Technical data

Technical data	Designation	Value
Input	Pt100 ($\alpha=0.00385$) IEC 60751	-200...+850°C / -328...+1562°F
	Pt100 ($\alpha=0.003916$) JIS C 1604-81	-200...+850°C / -328...+1562°F
	Pt X ($\alpha=0.00385$) IEC 60751	Corresponding to max. 4000 Ω
	Ni100 ($\alpha=0.006180$) DIN 43760	-60...+250°C / -76...+482°F
Edison curve 7	Ni120 ($\alpha=0.006720$)	-60...+250°C / -76...+482°F
	Ni1000 ($\alpha=0.006180$) DIN 43760	-50...+180°C / -58...+356°F
Edison copper winding No.15	Cu10 ($\alpha=0.004274$)	-50...+200°C / -58...+392°F
	Potentiometer	100...4000 Ω
	Thermocouples	Types: B, C, D, E, J, K, N, R, S, T
	Voltage	-10...1000 mV
	Sensor current	~0.3 mA
	Sensor wire resistance	20 Ω /wire for 2-wire connection 50 Ω /wire for 3/4-wire connection 10000 Ω for thermocouple
	Minimum span	10 Ω / 10°C / 2 mV
Monitoring	Sensor break function	Off, upscale or downscale ¹⁾
	Sensor short-circuit	Off, upscale, downscale ¹⁾
	Sensor drift	Off, upscale, downscale ¹⁾
Output	Temperature linear for RTD & T/C	4...20 mA, 20...4 mA or customized
	Response time	Single input approx. 300 ms, dual input approx. 600 ms
	Permissible load	635 Ω at 24 VDC incl. 250 Ω loop resistance
Ambient temperature	Operating	See Table 21
Humidity		5...95% RH
Vibrations		Acc. to IEC 68-2-6, Test Fc, 10g
Shock		Acc. to IEC 60068-2-31, test Ec
EMC	Standards	EN 61326-1:2006, EN 61326-3-1:2008, NAMUR NE21:2004
(EMC Directive 2004/108/EC)	Immunity performance	ESD, Radiated EM-field: Criteria A Surge: ~0.5% of span
Galvanic isolation		1500 VAC, 1 min
Power supply	R520X	10...30 VDC, polarity protected
Typical accuracy	For more information see RTD and T/C accuracy table 22	$\pm 0.1^\circ\text{C}$ / $\pm 0.2^\circ\text{F}$
Mounting		DIN rail EN 50022

¹⁾ Upscale (≥ 21.0 mA) or downscale (≤ 3.6 mA)

Table 19: R520X specifications

6.4.2 Output load diagram

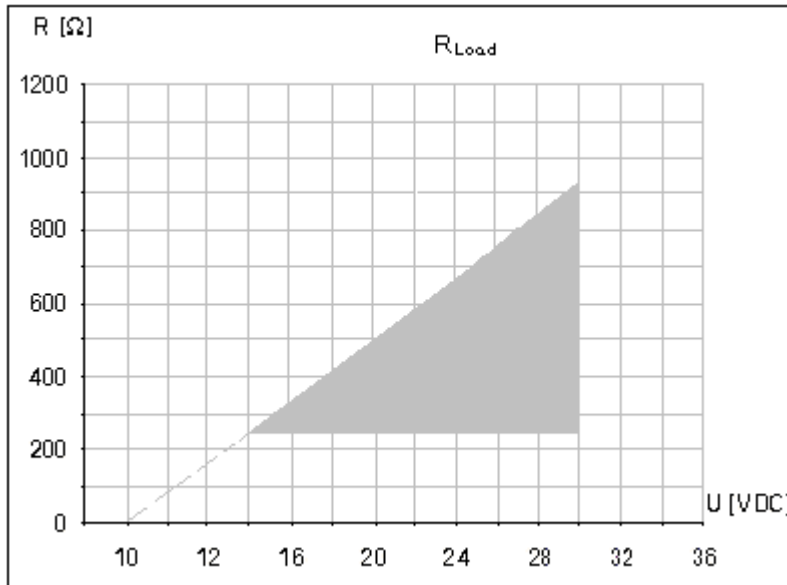

Figure 25: R520X output load diagram

Formula for the maximum permissible output load: R520X permissible $R_{Load} (\Omega) = (U-10)/0.022$

R	Total output load [Ω]
U	Power supply [VDC]

6.4.3 Dimensions

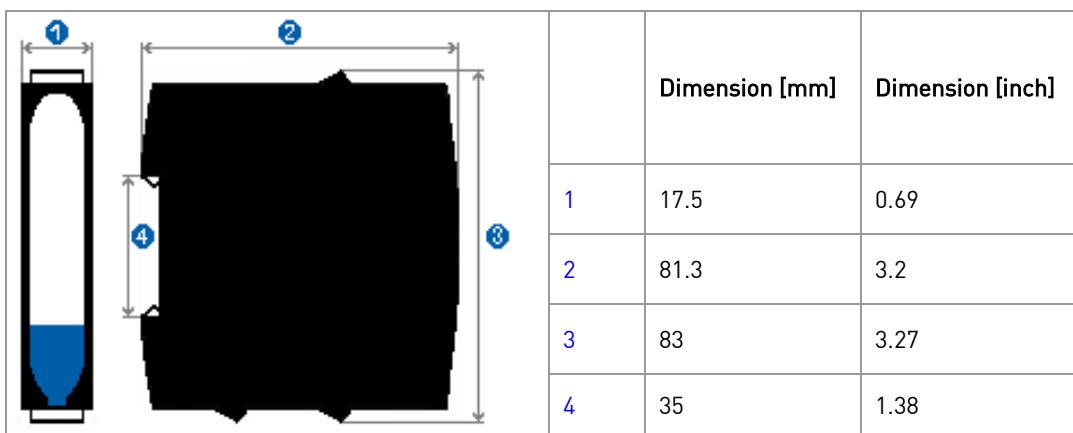

Figure 26: R520X dimensions

6.4.4 Output and input data



Output terminals 21, 22		Input terminals 1 to 8	
$U_i = V_{max}$:	≤ 30 VDC	$U_o = V_{oc}$:	≤ 6.6 VDC
$I_i = I_{max}$:	≤ 100 mA	$I_o = I_{sc}$:	≤ 27.3 mA
$P_i = P_{max}$:	≤ 900 mW	P_o :	≤ 46 mW
L_i :	$10 \mu\text{H}$	L_o :	25 mH
C_i :	12.1 nF	C_o :	$11 \mu\text{F}$

Table 20: Electrical data for outputs-inputs of R520X

6.4.5 Ambient temperature data for areas with potentially explosive atmospheres



Temperature class	Ambient temperature
T6	$-20^\circ\text{C} \leq T_a \leq +60^\circ\text{C} / -4^\circ\text{F} \leq T_a \leq +140^\circ\text{F}$
T5	$-20^\circ\text{C} \leq T_a \leq +70^\circ\text{C} / -4^\circ\text{F} \leq T_a \leq +158^\circ\text{F}$
T4	$-20^\circ\text{C} \leq T_a \leq +70^\circ\text{C} / -4^\circ\text{F} \leq T_a \leq +158^\circ\text{F}$

Table 21: R520X temperature data

6.5 RTD and T/C accuracy table for C520/C520X / R520/R520X transmitters

CJC error not included.
Conformance level 95% (2 σ)

Input type	Temp. range	Min span	Accuracy Max of:	Temp. influence (Dev. fr. ref.temp. 20°C)
RTD Pt100	-200...+850°C	10°C	$\pm 0.10^\circ\text{C}$ or $\pm 0.05\%$ of span	$\pm 0.005\%$ of span per K
RTD Pt1000	-200...+850°C	10°C	$\pm 0.10^\circ\text{C}$ or $\pm 0.05\%$ of span	$\pm 0.005\%$ of span per K
RTD PtX	Corr. to max. 4 k Ω	10°C	$\pm 0.10^\circ\text{C}$ or $\pm 0.05\%$ of span	$\pm 0.005\%$ of span per K
RTD Ni100	-60...+250°C	10°C	$\pm 0.10^\circ\text{C}$ or $\pm 0.05\%$ of span	$\pm 0.005\%$ of span per K
RTD Ni120	-60...+250°C	10°C	$\pm 0.10^\circ\text{C}$ or $\pm 0.05\%$ of span	$\pm 0.005\%$ of span per K
RTD Ni1000	-50...+180°C	10°C	$\pm 0.10^\circ\text{C}$ or $\pm 0.05\%$ of span	$\pm 0.005\%$ of span per K
RTD Cu10	-50...+260°C	83°C	$\pm 1.5^\circ\text{C}$ or $\pm 0.1\%$ of span	$\pm 0.01\%$ of span per K
T/C type B	+400...+1800°C	700°C	$\pm 1^\circ\text{C}$ or $\pm 0.1\%$ of span	$\pm 0.005\%$ of span per K
T/C type C	0...+2315°C	200°C	$\pm 1^\circ\text{C}$ or $\pm 0.1\%$ of span	$\pm 0.005\%$ of span per K
T/C type D	0...+2315°C	200°C	$\pm 1^\circ\text{C}$ or $\pm 0.1\%$ of span	$\pm 0.005\%$ of span per K
T/C type E	-200...+1000°C	50°C	$\pm 0.25^\circ\text{C}$ or $\pm 0.1\%$ of span	$\pm 0.005\%$ of span per K
T/C type J	-200...+1000°C	50°C	$\pm 0.25^\circ\text{C}$ or $\pm 0.1\%$ of span	$\pm 0.005\%$ of span per K
T/C type K	-200...+1350°C	50°C	$\pm 0.25^\circ\text{C}$ or $\pm 0.1\%$ of span	$\pm 0.005\%$ of span per K
T/C type N	-100...+1300°C	100°C	$\pm 0.25^\circ\text{C}$ or $\pm 0.1\%$ of span	$\pm 0.005\%$ of span per K
T/C type N	-250...+100°C	100°C	$\pm 1^\circ\text{C}$	$\pm 0.05\%$ of span per K
T/C type R	-50...+1750°C	300°C	$\pm 1^\circ\text{C}$ or $\pm 0.1\%$ of span	$\pm 0.005\%$ of span per K
T/C type S	-50...+1750°C	300°C	$\pm 1^\circ\text{C}$ or $\pm 0.1\%$ of span	$\pm 0.005\%$ of span per K
T/C type T	-200...+400°C	50°C	$\pm 0.25^\circ\text{C}$ or $\pm 0.1\%$ of span	$\pm 0.005\%$ of span per K

Table 22: RTD and T/C accuracy table for the C520/C520X / R520/R520X transmitters

7.1 Ordering information

Designation	Order No.
C520	70C5200010
C520, SIL 2 compatible	70C5200S10
C520N	70C520N010
C520X	70C520X010
C520X, SIL 2 compatible	70C520XS10
R520	70R5200010
R520, SIL 2 compatible	70R5200S10
R520N	70R520N010
R520X	70R520X010
R520X, SIL 2 compatible	70R520XS10
ICON, PC configuration kit (USB-connection)	70CFGUS001
Head mounting kit	70ADA00017
DIN-rail adapter	70ADA00015
Configuration ex works	70CAL00001

Table 23: Ordering information

7.2 Disposal

To address proper recovery, recycling, and disposal of customer end-of-life electronic equipment that is consistent with legislative or regulatory requirements, product and packaging materials should be disposed according with the respective waste treatment and disposal regulations of the region or country to which the device is supplied.

This product should not be mixed with other kind of scrap, after usage. It should be handled as an electronic/electric device.



7.3 Maintenance

The C520/C520X / R520/R520X are completely encapsulated; therefore there are no components, which could be repaired or replaced.

7.4 Product liability and guarantee

Use of IPAQ 520 series transmitters for other than the intended purpose or improper installation and operation may lead to loss of the guarantee. The guarantee shall likewise be void if the device is damaged or its function otherwise impaired.

INOR Process AB, or any other affiliated company within the INOR Group (hereinafter jointly referred to as "INOR"), hereby warrants that the Product will be free from defects in materials or workmanship for a period of five (5) years from the date of delivery ("Limited Warranty"). This Limited Warranty is limited to repair or replacement at INOR's option and is effective only for the first end-user of the Product. Upon receipt of a warranty claim, INOR shall respond within a reasonable time period as to its decision concerning:

- 1 Whether INOR acknowledges its responsibility for any asserted defect in materials or workmanship; and, if so,
- 2 the appropriate cause of action to be taken (i.e. whether a defective product should be replaced or repaired by INOR).

This Limited Warranty applies only if the Product:

- 1 is installed according to the instructions furnished by INOR;
- 2 is connected to a proper power supply;
- 3 is not misused or abused; and
- 4 there is no evidence of tampering, mishandling, neglect, accidental damage, modification or repair without the approval of INOR or damage done to the Product by anyone other than INOR.

This Limited Warranty is provided by INOR and contains the only express warranty provided. INOR SPECIFICALLY DISCLAIMS ANY EXPRESS WARRANTY NOT PROVIDED HEREIN AND ANY IMPLIED WARRANTY, GUARANTEE OR REPRESENTATION AS TO SUITABILITY FOR ANY PARTICULAR PURPOSE, PERFORMANCE, QUALITY AND ABSENCE OF ANY HIDDEN DEFECTS, AND ANY REMEDY FOR BREACH OF CONTRACT, WHICH BUT FOR THIS PROVISION, MIGHT ARISE BY IMPLICATION, OPERATION OF LAW, CUSTOM OF TRADE OR COURSE OF DEALING, INCLUDING IMPLIED WARRANTIES OF MERCHANTABILITY AND FITNESS FOR A PARTICULAR PURPOSE. EXCEPT AS PROVIDED HEREIN, INOR FURTHER DISCLAIMS ANY RESPONSIBILITY FOR LOSSES, EXPENSES, INCONVENIENCES, SPECIAL, DIRECT, SECONDARY OR CONSEQUENTIAL DAMAGES ARISING FROM OWNERSHIP OR USE OF THE PRODUCT.

Products that are covered by the Limited Warranty will either be repaired or replaced at the option of INOR. Customer pays freight to INOR, and INOR will pay the return freight by post or other "normal" way of transport. If any other type of return freight is requested, customer pays the whole return cost.

7.5 Support

Inor Process AB PO Box 9125 SE-200 39 MALMÖ Sweden Phone: +46-(0)40-31 25 60 Fax: +46-(0)40-31 25 70 E-mail: support@inor.se	Inor Transmitter Oy Unikkotie 13 FI-01300 VANTAA Finland Phone: +358-(0)10-4217900 Fax: +358-(0)10-4217901 E-mail: jari.stadig@inor.fi	Inor Transmitter GmbH Am Bocksborn 5 63571 Gelnhausen Germany Phone: +49-(0)6051-14807 Fax: +49-(0)6051-14806 E-mail: support.de@inor.se
---	---	--



INOR

www.inor.com, www.inor.se